



Montageanleitung
Mounting Instructions
Instructions de montage
Istruzioni di montaggio
Instrucciones de montaje

TS 220
TS 230

Warnhinweise · Warnings · Recommendations · Avvertenze · Advertencias



DIN EN 100 015 – 1
CECC 00015 – 1

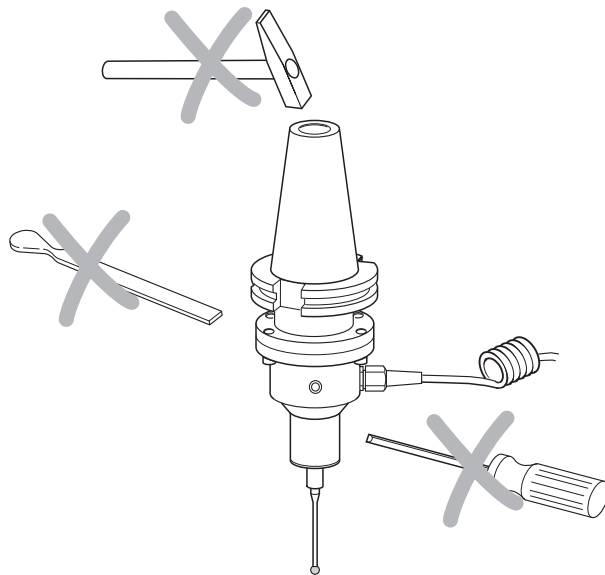
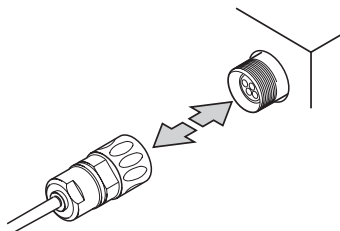
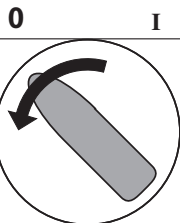

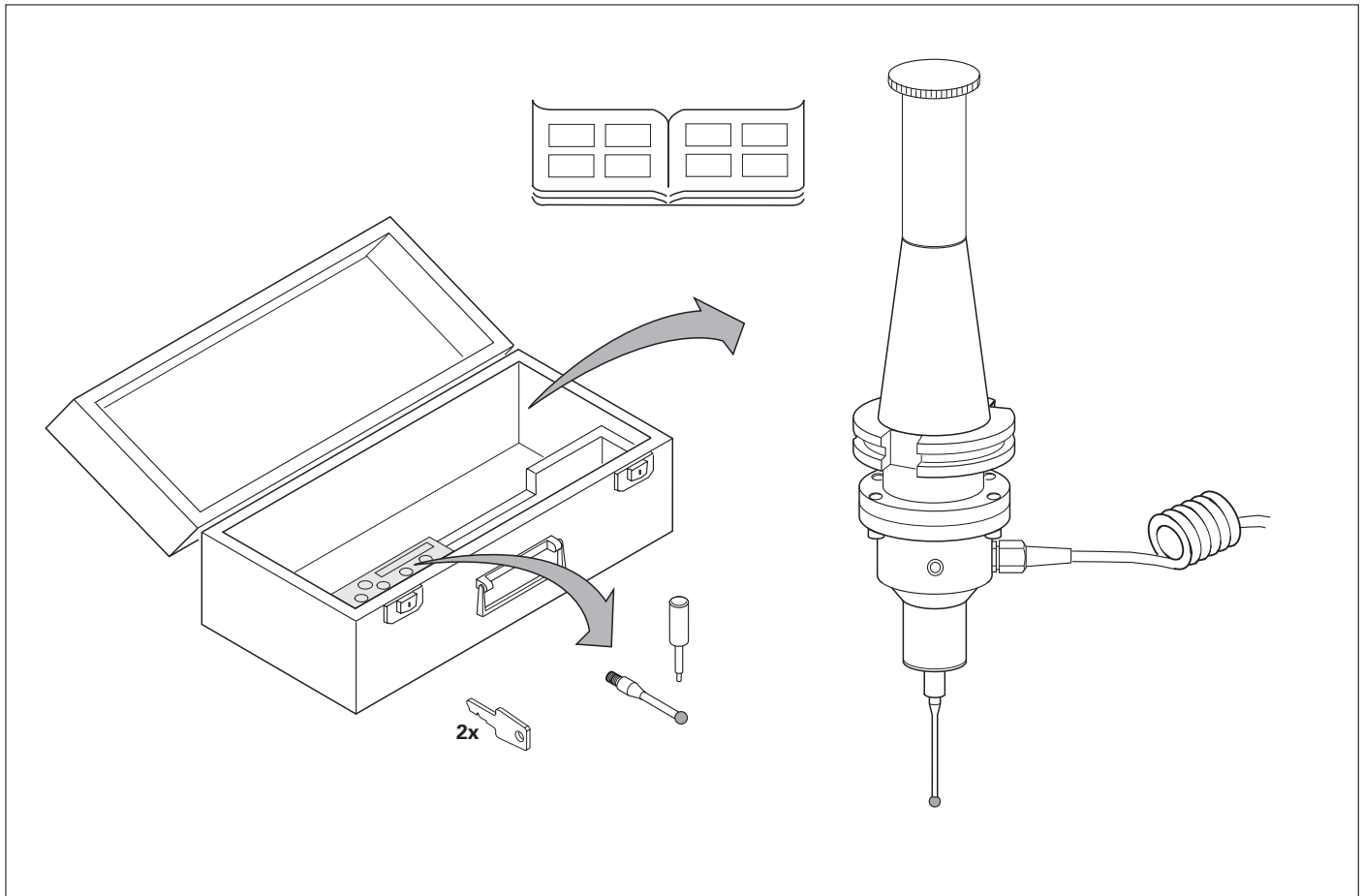

Abmessungen · Dimensions · Dimensions · Dimensioni · Dimensiones

mm/inches



DIN ISO 8015

ISO 2768 - m H

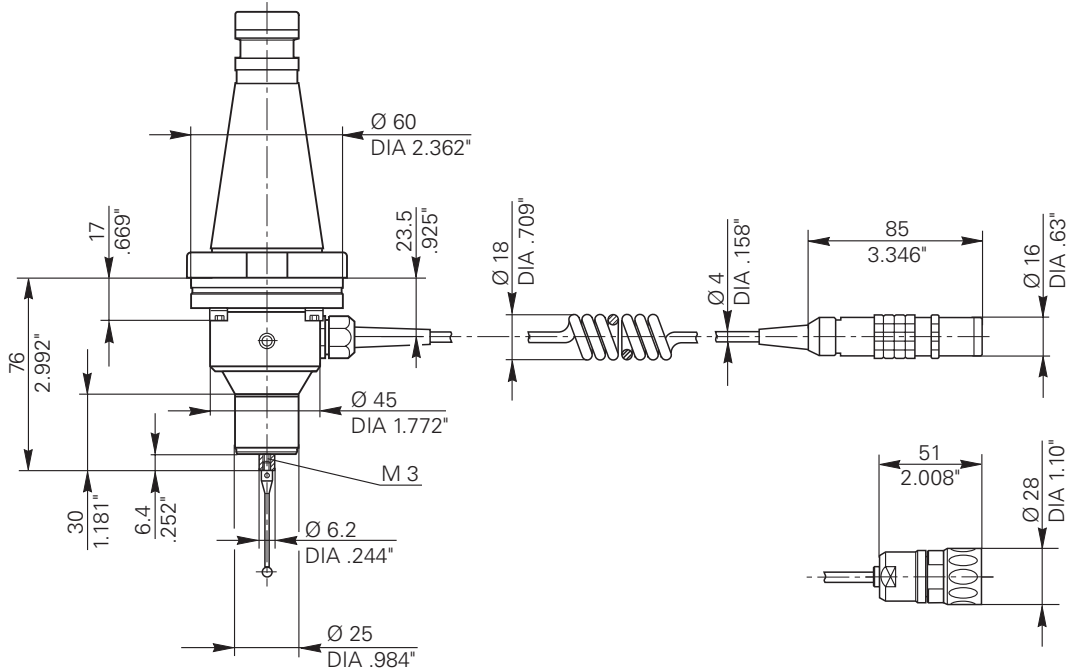

Abmessungen · Dimensions · Dimensions · Dimensioni · Dimensiones

mm/inches



DIN ISO 8015

ISO 2768 - m H

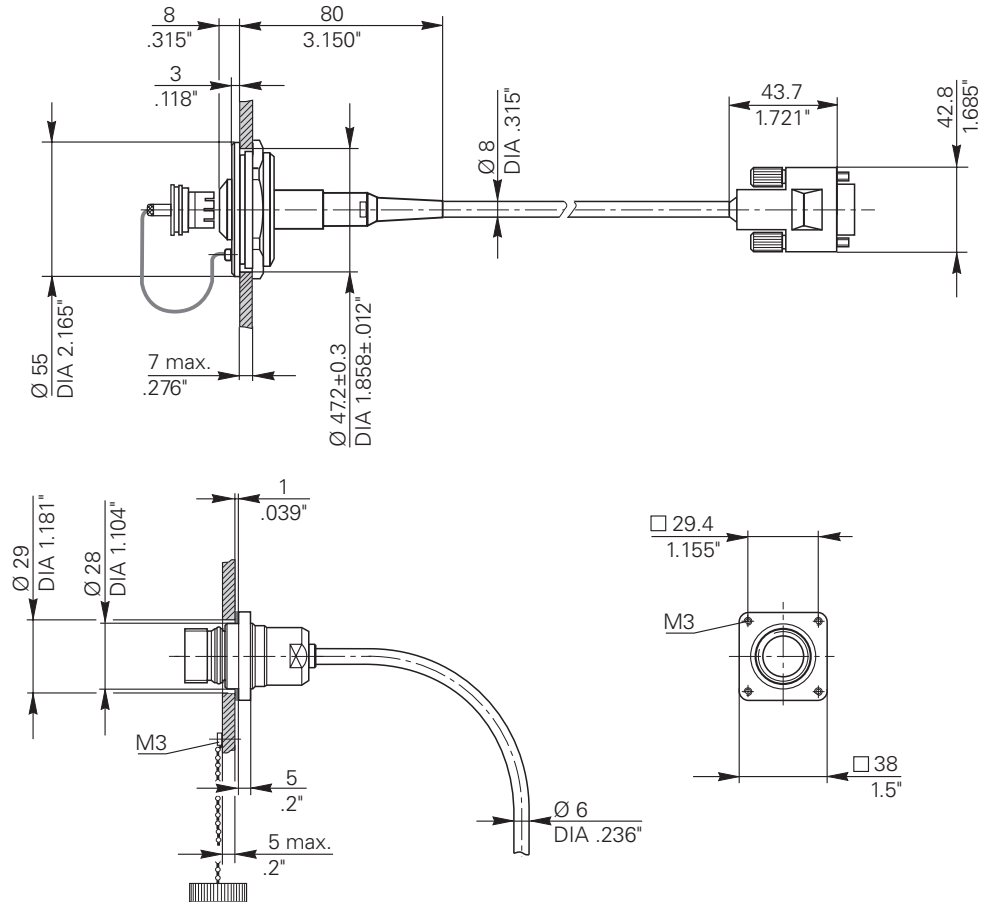

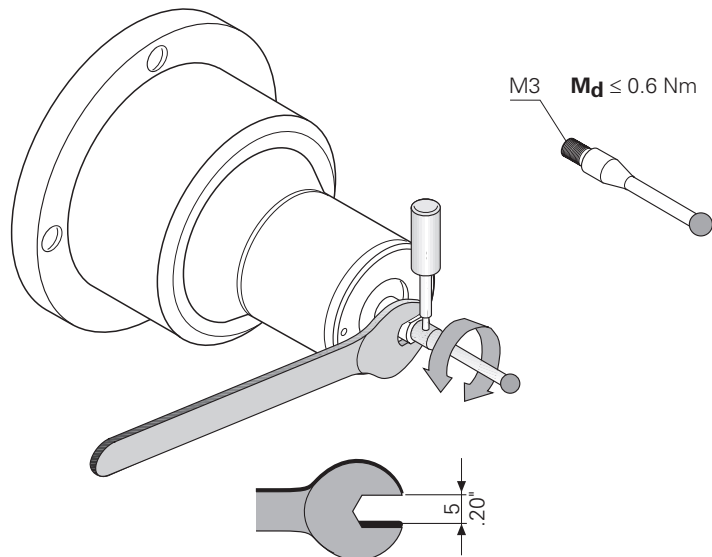

Schaftmontage · Shank assembly · Montage du cône de bridage · Montaggio del cono · Montaje del cono

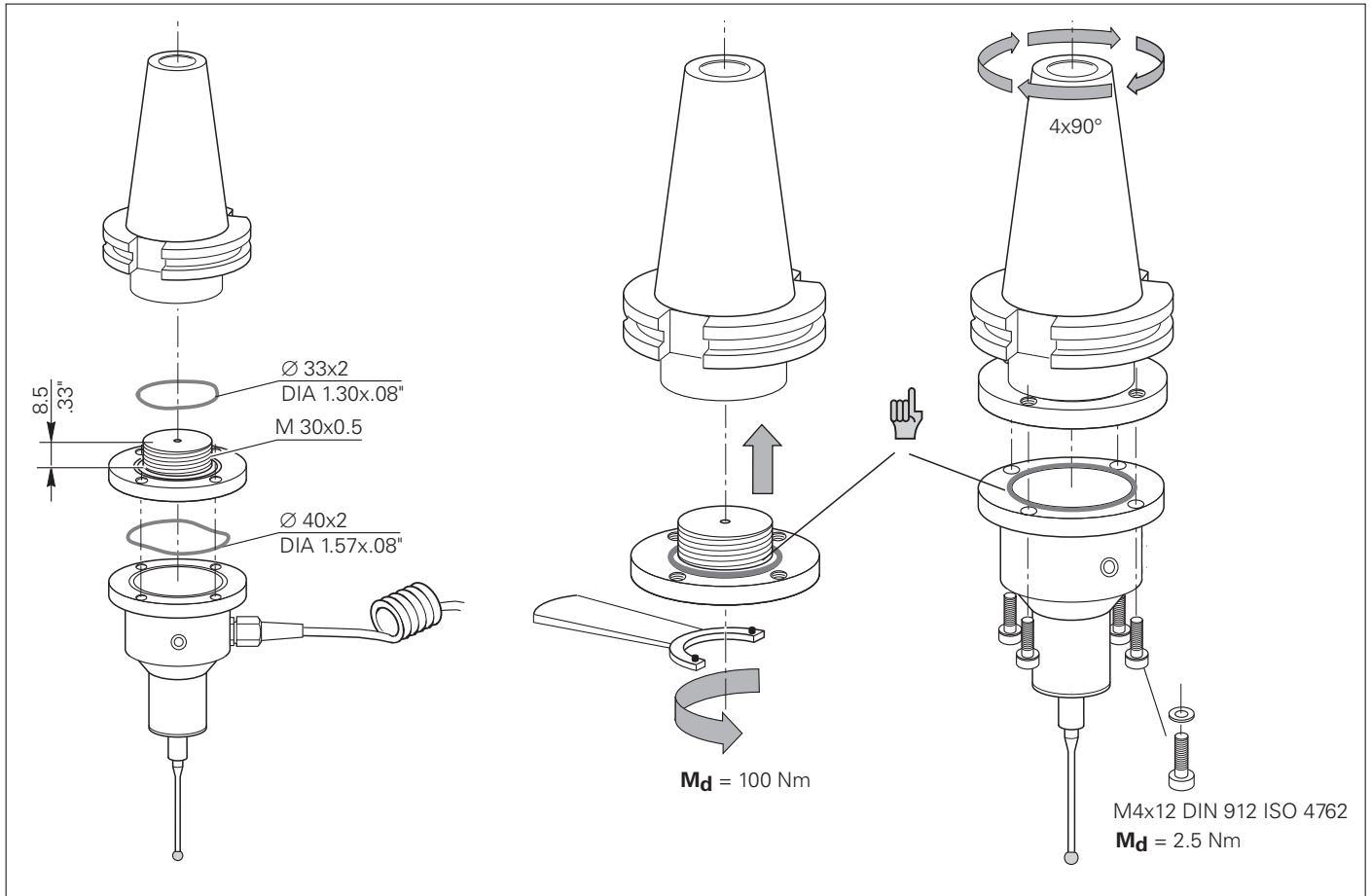

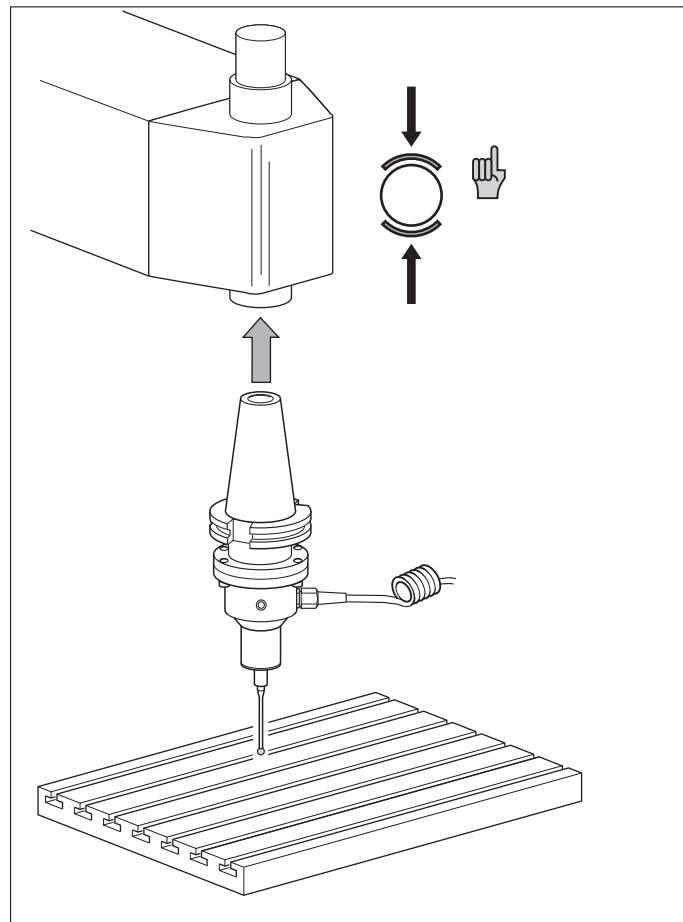
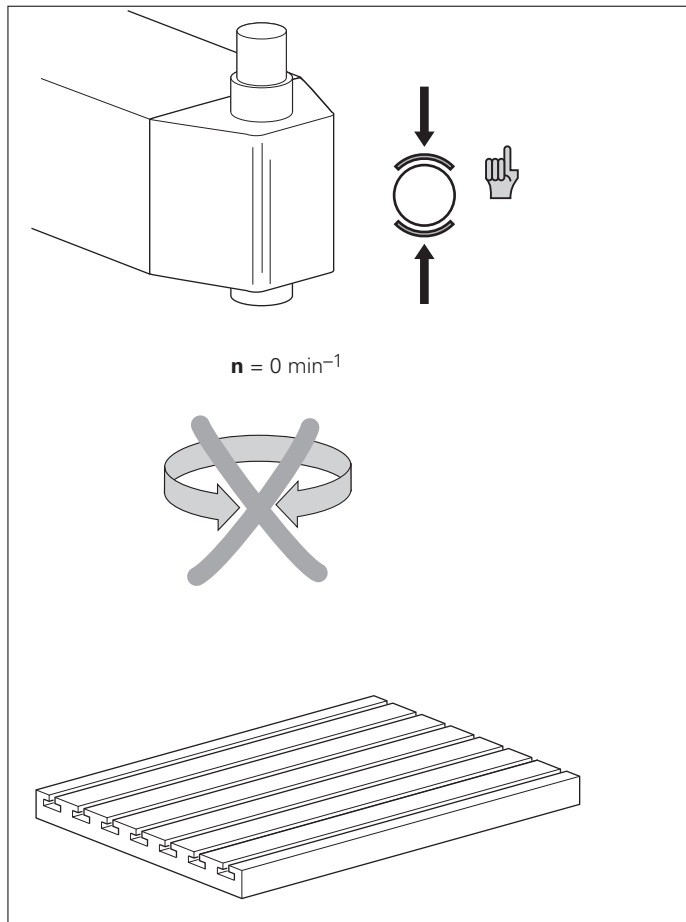

elektronisch
Electronic
électronique
elettronico
electrónico

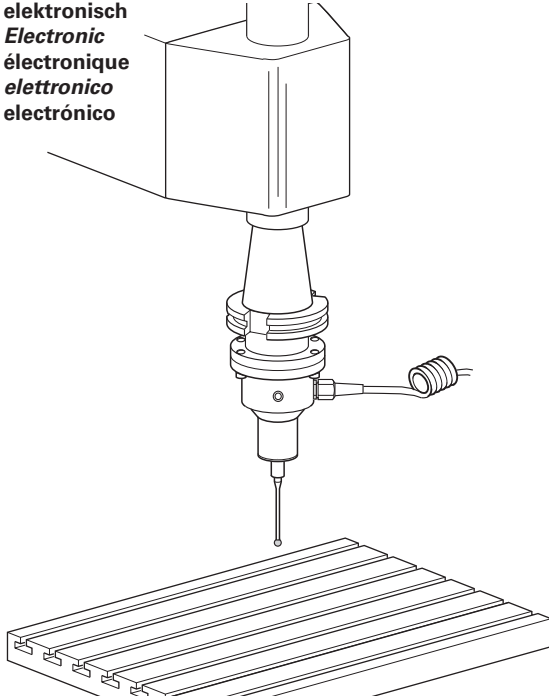

in NC durch Umschlagmessung (Kalibrierung)
in NC through probing from opposite orientations
dans la CN par mesure avec rotation dans les
deux sens à 180°(bague d'étalonnage)
tramite NC (anello di calibrazione)
en NC mediante medición indicada
(anillo de calibración)

mechanisch
Mechanical
mécanique
meccanico
mecánico

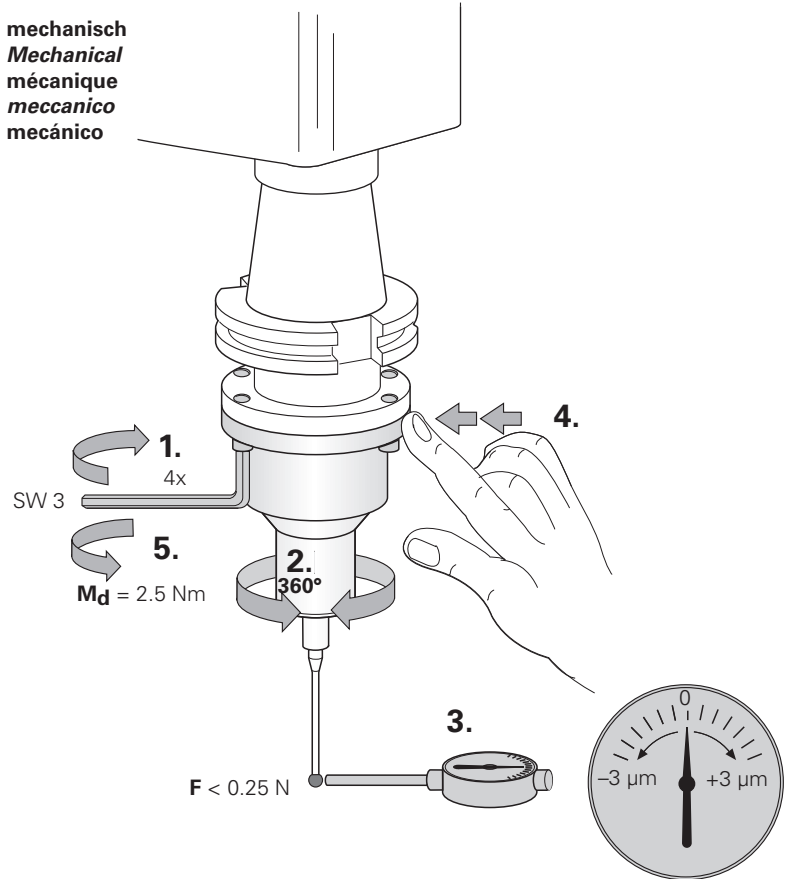

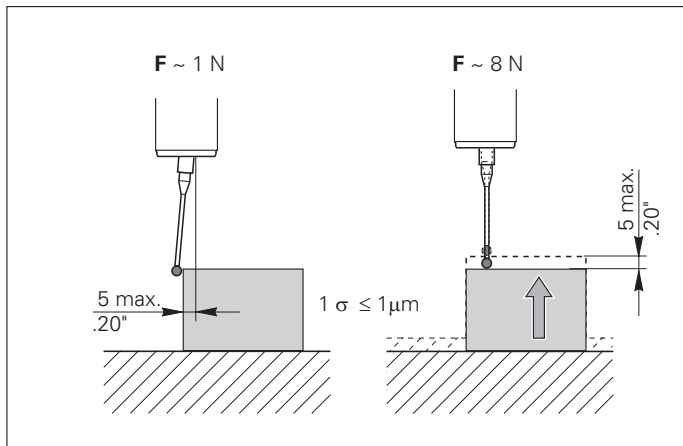
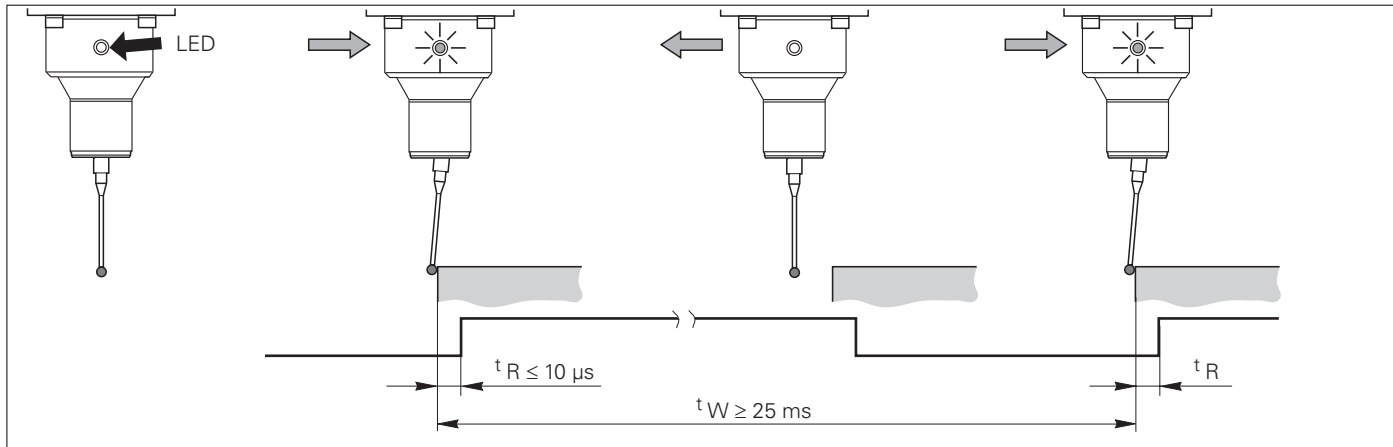

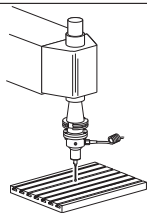
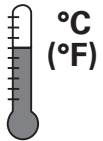

10 ... 40 °C
(50 ... 104 °F)

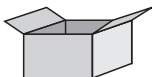

-20 ... 70 °C
(- 4 ... 158 °F)

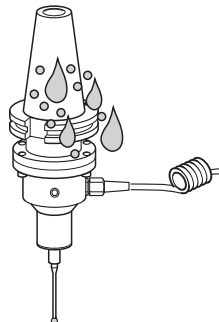

IP 55
IEC 529
EN 60 529

TS 220

$U_P = 5 V \pm 5 \%$
(max. 100 mA)

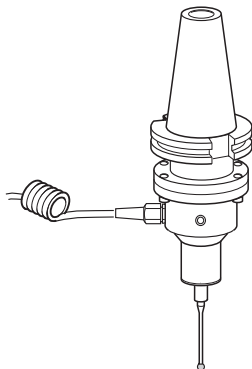

 IEC 742
EN 50 178

TS 230

$U_P = 10 \dots 30 V$
(max. 100 mA)

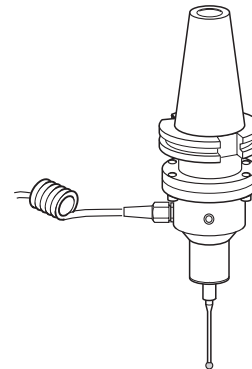

 IEC 742
EN 50 178

TS 220

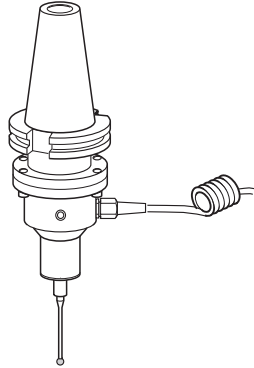

TTL

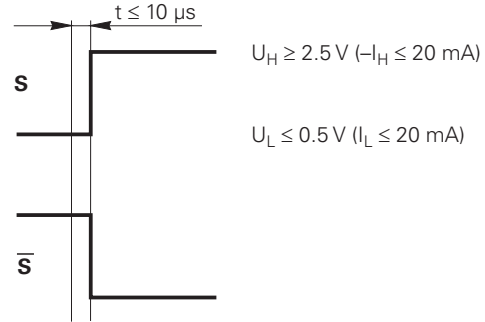

TS 230

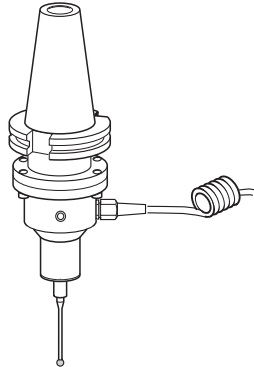

HTL

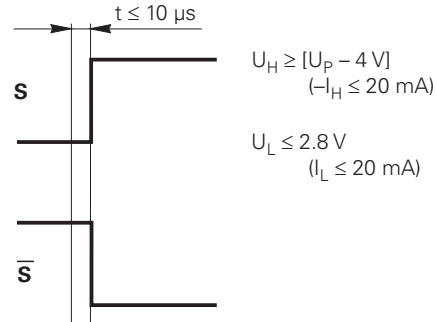

S, \bar{S} = Schaltsignal
Trigger signal
Signal de commutation
Segnale di commutazione
Señal de conexión

Elektrischer Anschluß · *Electrical connection* · Raccordement électrique · *Collegamento elettrico* · Conexión eléctrica

TS 220



1,2,4,11-15
nicht belegt
Not used
non attribué
non occupato
no ocupado

1	2	3	4	5	6
0V U _N	5V U _P	S	S̄		
weiß <i>white</i> blanc <i>blanc</i> <i>bianco</i> blanco	braun <i>brown</i> brun <i>marrone</i> marrón	grün <i>green</i> vert <i>verde</i> verde	gelb <i>yellow</i> jaune <i>giallo</i> amarillo	/	/

IEC 742 EN 50 178

3	5	7	6	8	9	10
			5V U _P	0V U _N	S	S̄
rosa <i>pink</i> rose <i>rosa</i> rosa	–	grau <i>gray</i> gris <i>grigio</i> gris	braun/grün <i>brown/green</i> brun/vert <i>marrone/verde</i> marrón/verde	weiß/grün <i>white/green</i> blanc/vert <i>bianco/verde</i> blanco/verde	grün <i>green</i> vert <i>verde</i> verde	gelb <i>yellow</i> jaune <i>giallo</i> amarillo

IEC 742 EN 50 178

TS 220

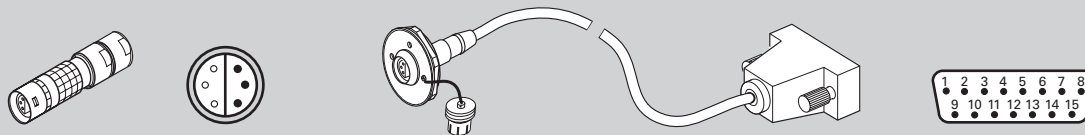

1,2,4,11-15
nicht belegt
Not used
non attribué
non occupato
no ocupado

1	2	3	4	5	6
0V U _N	5V U _P			S	S̄
weiß <i>white</i> blanc <i>blanc</i> <i>bianco</i> blanco	braun <i>brown</i> brun <i>marrone</i> marrón	/	/	grün <i>green</i> vert <i>verde</i> verde	gelb <i>yellow</i> jaune <i>giallo</i> amarillo

IEC 742 EN 50 178

3	5	7	6	8	9	10
			5V U _P	0V U _N	S	S̄
rosa <i>pink</i> rose <i>rosa</i> rosa	/	grau <i>gray</i> gris <i>grigio</i> gris	braun/grün <i>brown/green</i> brun/vert <i>marrone/verde</i> marrón/verde	weiß/grün <i>white/green</i> blanc/vert <i>bianco/verde</i> blanco/verde	grün <i>green</i> vert <i>verde</i> verde	gelb <i>yellow</i> jaune <i>giallo</i> amarillo

IEC 742 EN 50 178

TS 230

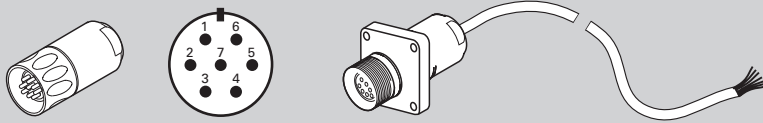

1	2	3	4	5	6	7
0V U _N	10 ... 30V U _P	S	\bar{S}			/
weiß white blanc bianco blanco	braun brown brun marrone marrón	grün green vert verde verde	gelb yellow jaune giallo amarillo	/	/	/

IEC 742 EN 50 178

				(5)	(6)
0V U _N	10 ... 30V U _P	S	\bar{S}	- - - -	
weiß/grün white/green blanc/vert bianca/verde blanco/verde	braun/grün brown/green brun/vert marrone/verde marrón/verde	braun brown brun marrone marrón	grün green vert verde verde	grau gray gris grigio gris	rosa pink rose rosa rosa

IEC 742 EN 50 178

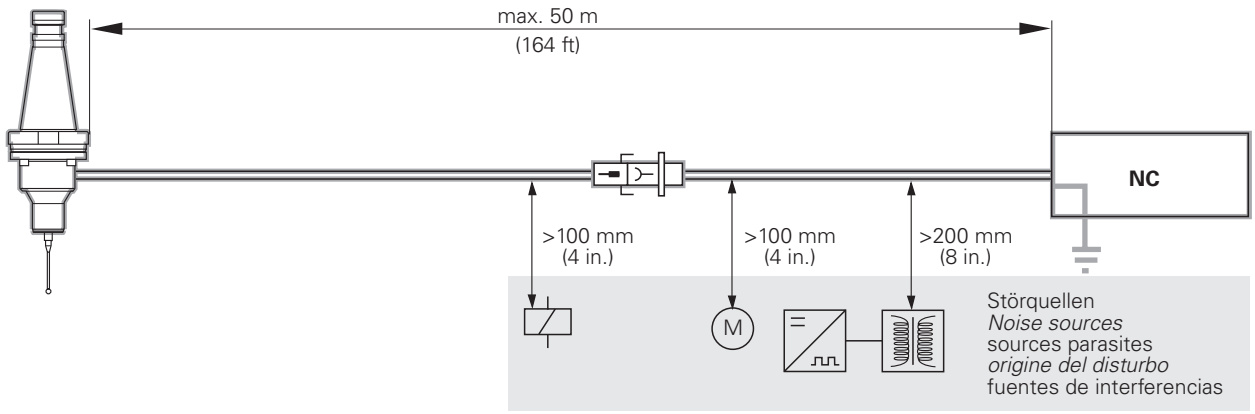

HEIDENHAIN

DR. JOHANNES HEIDENHAIN GmbH

Dr.-Johannes-Heidenhain-Straße 5

83301 Traunreut, Germany

 +49/86 69/31-0

 +49/86 69/50 61

e-mail: info@heidenhain.de

 **Service** +49/86 69/31-12 72

 TNC-Service +49/86 69/31-14 46

 +49/86 69/98 99

e-mail: service@heidenhain.de

www.heidenhain.de

