



HEIDENHAIN

Montageanleitung
Mounting Instructions
Instructions de montage
Istruzioni di montaggio
Instrucciones de montaje

TS 649

3/2013

Inhalt
Contents
Sommaire
Indice
Indice

Seite	
4	Warnhinweise
6	Lieferumfang
7	Abmessungen
8	Kegelmontage
9	Taststiftwechsel
10	Batterienwechsel
12	Zentrieren
14	Technische Kennwerte
15	Signalfolge

Page	
4	<i>Warnings</i>
6	<i>Items Supplied</i>
7	<i>Dimensions</i>
8	<i>Taper Mounting</i>
9	<i>Stylus Exchange</i>
10	<i>Battery Exchange</i>
12	<i>Centering</i>
14	<i>Specifications</i>
15	<i>Signal Sequence</i>

Page	
4	Avertissement
6	Contenu de la fourniture
7	Dimensions
8	Montage du cône
9	Changement de la tige de palpée
10	Changement des batteries
12	Centrage
14	Caractéristiques techniques
15	Diagramme des signaux

Pagina	
4	<i>Avvertenze</i>
6	<i>Standard di fornitura</i>
7	<i>Dimensioni</i>
8	<i>Montaggio del cono</i>
9	<i>Sostituzione dello stilo</i>
10	<i>Sostituzione delle batterie</i>
12	<i>Centraggio</i>
14	<i>Dati tecnici</i>
15	<i>Treno di segnali</i>

Página	
4	Notas de aviso
6	Elementos suministrados
7	Dimensiones
8	Montaje del cono
9	Cambio del vástago
10	Cambio de la batería
12	Centrado
14	Información técnica
15	Secuencia de la señal

Warnhinweise
Warnings
Avertissement
Avvertenze
Notas de aviso



Achtung: Die Montage und Inbetriebnahme ist von einer qualifizierten Fachkraft unter Beachtung der örtlichen Sicherheitsvorschriften vorzunehmen.

Note: *Mounting and commissioning is to be conducted by a qualified specialist under compliance with local safety regulations.*

Attention: le montage et la mise en service doivent être assurés par un personnel qualifié dans le respect des consignes de sécurité locales.

Attenzione: *Il montaggio e la messa in funzione devono essere eseguite da personale qualificato nel rispetto delle norme di sicurezza locali.*

Atención: El montaje y la puesta en marcha deben ser realizados por un especialista cualificado, observando las prescripciones locales de seguridad.

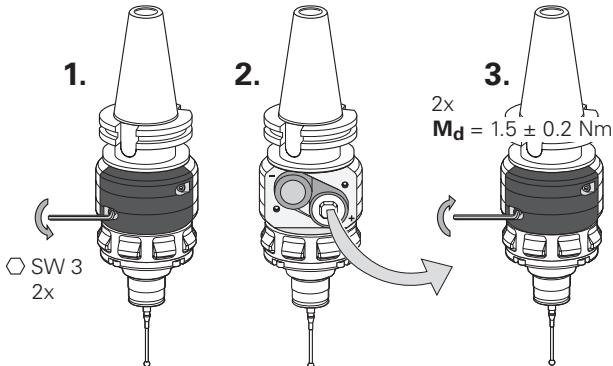

Vor erster Inbetriebnahme die Schutzkappe der Batterie entfernen.

Remove the battery's protective cap before initial operation.

Enlever le capot de protection de la batterie avant la première mise en service.

Prima della messa in funzione rimuovere la protezione della batteria.

Retirar la tapa de protección de la batería antes de la primera puesta en marcha.

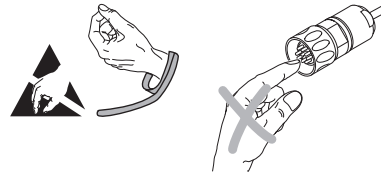

Tastsystem nicht fallen lassen.
Do not drop the touch probe.
Ne pas laisser tomber le palpeur.
Non far cadere il tastatore.
No dejar caer el palpador.

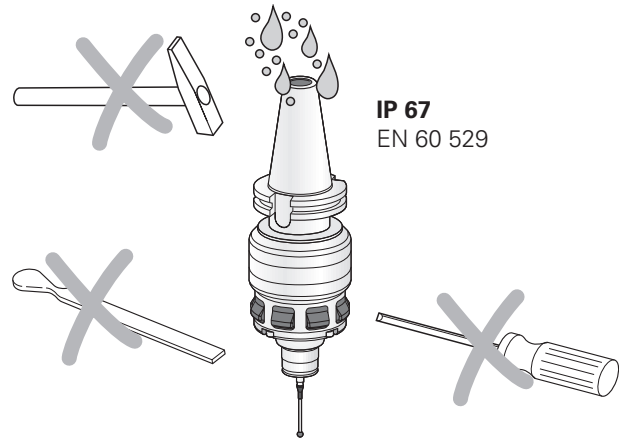

Lieferumfang
Items supplied
Objet de la fourniture
Standard di forniture
Suministro

Separat bestellen:
To be ordered separately:
Commander séparément:
Da ordinare separatamente:
Pedir por separado:

SE 640
ID 631225-xx



TS 649



ID 370827-01

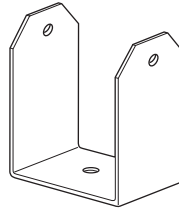

Halter für SE 640
Holder for SE 640
Support de SE 640
Supporto per SE 640
Soporte para SE 640

SE 540
ID 626001-xx



ID 519833-01

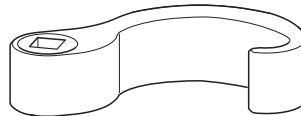

Schlüssel für Kegelmontage
Wrench for taper mounting
Clef pour le montage du cône
Chiavi per il montaggio dei coni
Llave para el montaje del cono

Abmessungen
Dimensions
Dimensioni
Dimensiones

mm



Tolerancing ISO 8015
ISO 2768 - m H
< 6 mm: ±0.2 mm

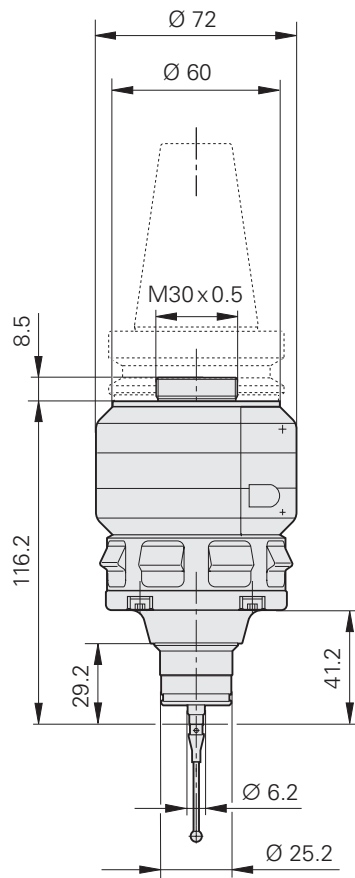

Kegelmontage
Taper mounting
Montage du cône
Montaggio del cono
Montaje del cono

TS 649 lösen
 Remove TS 649
 Dévisser le TS 649
 Allentare il TS 649
 Soltar el TS 649

TS 649 mit Drehmomentschlüssel anschrauben
 Attach TS 649 with torque wrench
 Visser le TS 649 avec une clef dynamométrique
 Avvitare il TS 649 con chiave dinamometrica
 Aatornillar el TS 649 con una llave dinamométrica

M30 x 0.5
 Gewinde mit Loctite 222/S8 sichern
 Secure the thread with Loctite 222/S8
 Freinage des filetages avec Loctite 222/S8
 Bloccare il filetto con Loctite 222/S8
 Asegurar la rosca con Loctite 222/S8

$M_d = 80 \pm 5 \text{ Nm}$

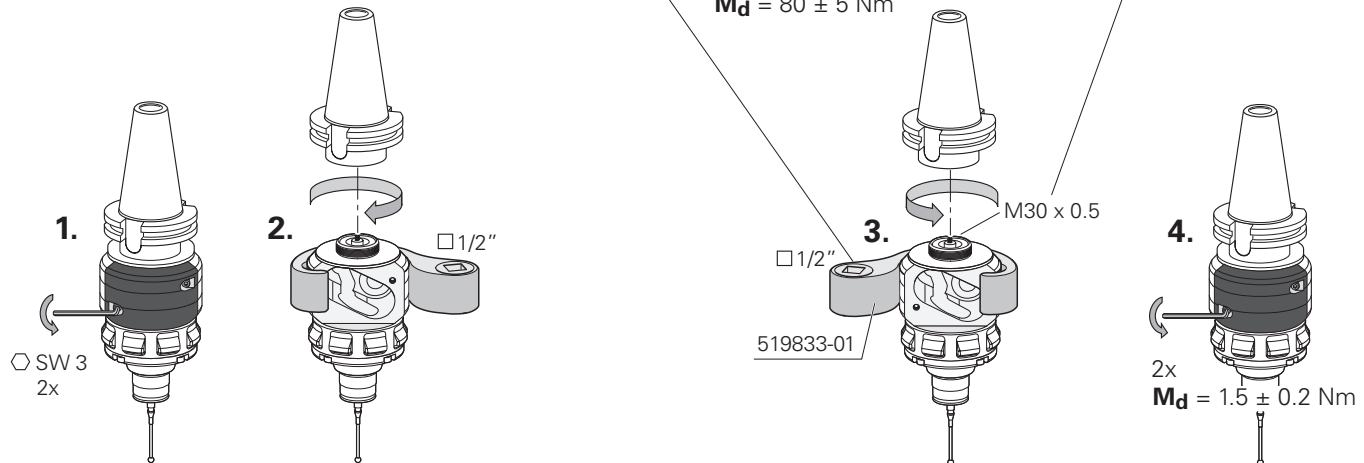

Taststiftwechsel
Stylus exchange
Changement de la tige de palp
Sostituzione dello stilo
Cambio del vástago



Achtung: Neu zentrieren, siehe Seite 12 und 13

Note: Recenter, see pages 12 and 13

Attention: recentrage, voir pages 12 et 13

Attenzione: ripetere il centraggio, vedere pagina 12 e 13

Atención: centrar de nuevo, ver pág. 12 y 13

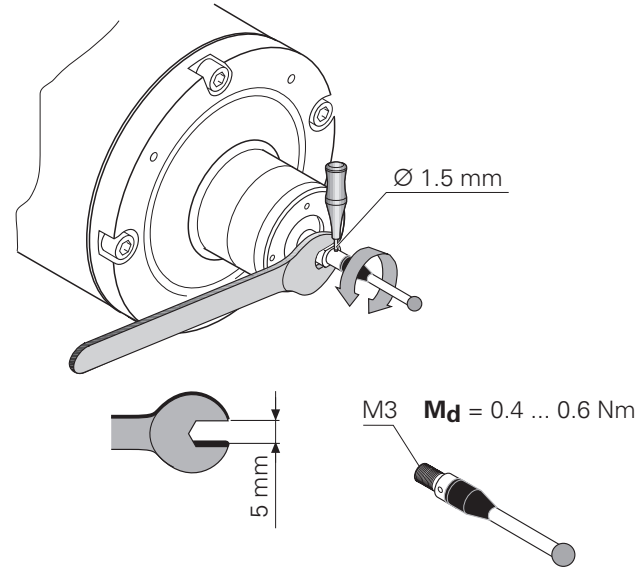

Batterienwechsel
Battery exchange
Changement des batteries
Sostituzione delle batterie
Cambio de baterias

Wegen Selbstkalibrierung muss Taststift frei sein
The stylus must hang loose for the self-calibration
La tige de palpation doit être libre à cause de l'auto-calibration
Lo stilo deve essere libero per autocalibrazione
Por motivo de la autocalibración, el vástago debe estar suelto

Im Lieferumfang enthalten: 2 Stück Batterien LITHIUM 3.6 V Form A
ID 332 775-04, plus 2 Stück Adapter ID 722 383-01. (Batterien nicht aufladbar)
Included in the delivery: 2 LITHIUM batteries, 3.6 V, size A
ID 332 775-04, with 2 adapters ID 722 383-01. (Batteries not rechargeable)
Inclus dans la fourniture: 2 x batteries LITHIUM 3.6 V Form A
ID 332 775-04, plus 2 x adaptateur ID 722 383-01. (Batteries non rechargeables)
Lo standard di fornitura comprende: 2x batterie LITHIUM 3,6 V formato A
ID 332 775-04, più 2x adattatori ID 722 383-01 (batterie non ricaricabili)
Contenido entre los elementos suministrados: 2x baterías LITHIUM 3.6 V Serie A
ID 332 775-04, más 2x adaptadores ID 722 383-01 (baterías no recargables)

Um die max. Betriebsdauer zu erreichen, beziehen sie bitte Batterien LITHIUM-ION Form C separat.
For maximum battery life, please order size C LITHIUM ION batteries separately.
Pour atteindre une durée de vie max, utilisez des batteries LITHIUM-ION Form C separat.
Per raggiungere la durata d'esercizio massima, acquistare separatamente batterie LITHIUM-ION formato C.
Para conseguir alcanzar el máximo tiempo de funcionamiento, pedir por separado baterías LITHIUM-ION serie C.

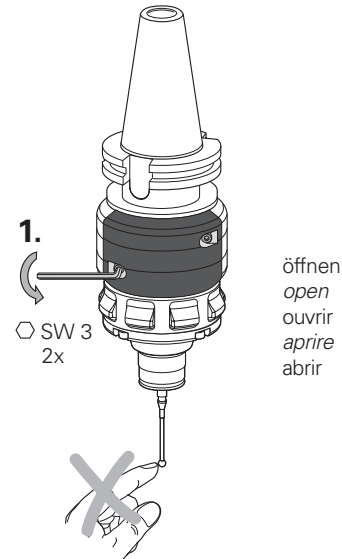

Alkaline-Batterien oder NiMH-Akkus mit 1 bis 4 V sind ebenfalls verwendbar
Alkaline batteries or NiMH accumulators with 1 to 4 V can also be used.
Utilisation possible des batteries alcalines ou accus NiMH de 1 à 4 V.
Possono essere impiegate batterie alcaline o NiMH da 1 a 4 V.
Asimismo pueden utilizarse baterías o acumuladores NiMH de 1 hasta 4 V.

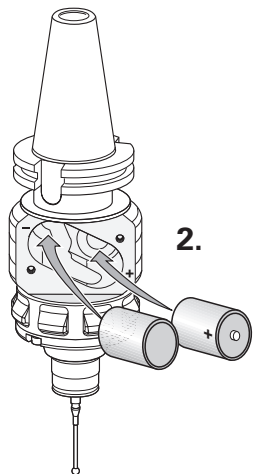

2x
 $M_d = 1.5 \pm 0.2 \text{ Nm}$

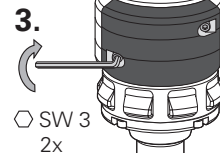

schließen
close
Fermer
chiudere
cerrar



Zentrieren
Centering
Centrage
Centraggio
Centrado

Elektronisch Zentrieren: in NC durch Umschlagmessung (Kalibrierring)
Electronic centering: In NC through probing from opposite directions (calibration ring)
Centrage électronique: dans la CN via rotation à 180° (bague d'étalonnage)
Centraggio elettronico: tramite NC eseguire la tastatura su due punti diametralmente opposti (anello di calibrazione)
Centrado electrónico: en NC a través del palpado en direcciones opuestas (anillo de calibración)

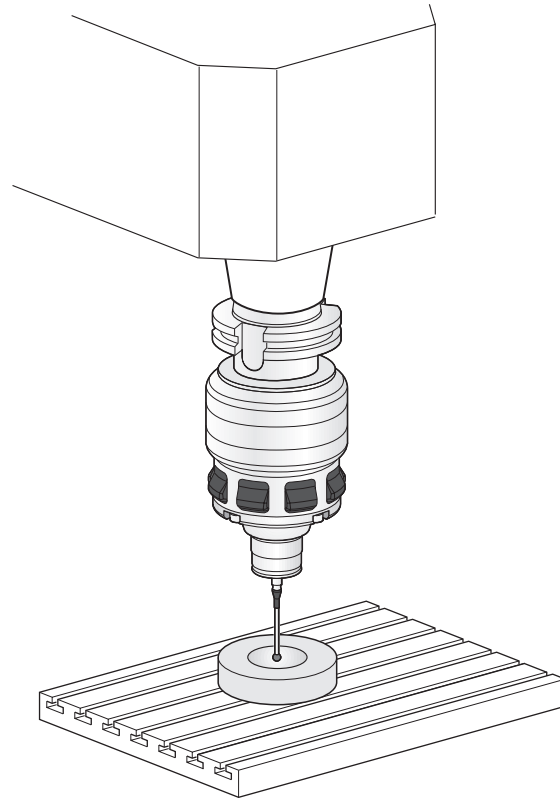

Spindel oder Werkzeugeinstellgerät
Spindle or tool-setting device
Broche ou banc de pré réglage d'outils
Mandrino o apparecchio di serraggio dell'utensile
Sistema de ajuste de la herramienta o del cabezal

Mechanisch Zentrieren, nur nötig wenn keine elektronische Zentrierung möglich ist.
Mechanical centering. Only necessary if electronic centering is not possible.
Centrage mécanique, seulement si le centrage électronique n'est pas possible.
Centraggio meccanico: necessario solo se non è possibile il centraggio elettronico.
Centrado mecánico, sólo requerido si no existe la posibilidad del centrado electrónico.

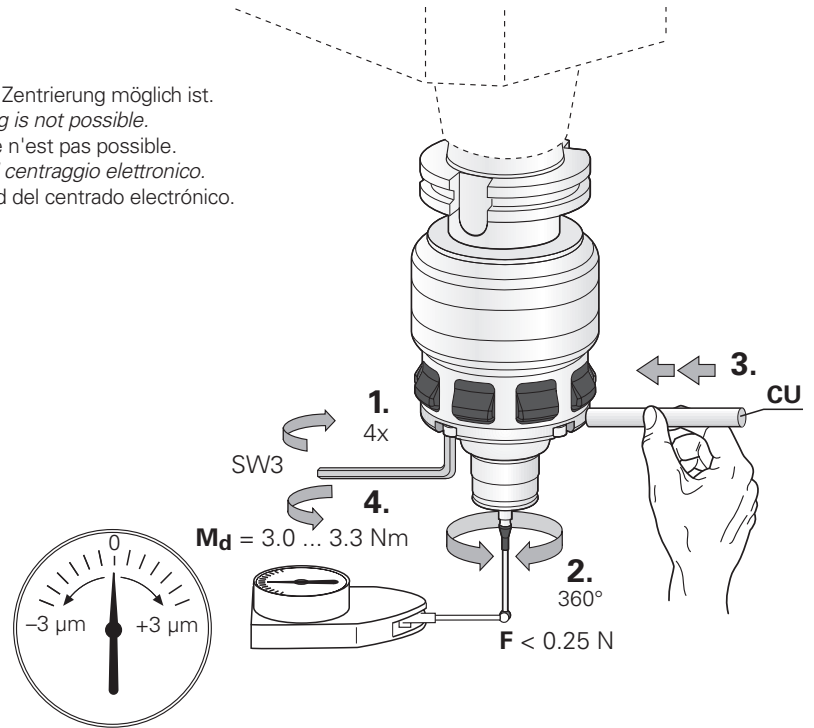

Technische Kennwerte
Specifications
Caractéristiques techniques
Dati tecnici
Características técnicas

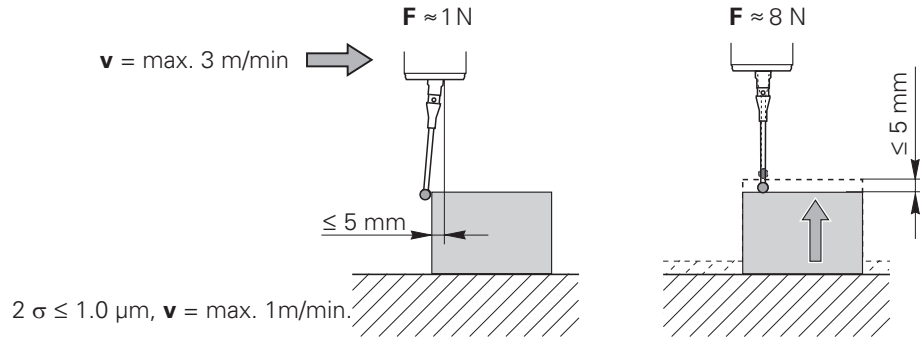

Zustand des Tastsystems
Status of the touch probe
 Etat du palpeur
Stato del sistema di tastatura
 Estado del sistema de palpación

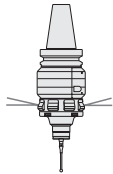

● rot blinkend
Red (blinking)
 rouge clignotant
 rosso lampeggiante
 rojo parpadeando

Tastsystem bereit, Taststift in Ruhelage
Touch probe ready, stylus at rest
 Palpeur prêt, tige de palpation au repos
sistema pronto, stilo in posizione di riposo
 Palpador preparado; vástago en posición de reposo

● rot Dauerleuchten
Red (permanently lit)
 rouge permanent
 rosso permanente
 rojo encendido continuo

Tastsystem bereit, Taststift ausgelenkt
Touch probe ready, stylus deflected
 Palpeur prêt, tige de palpation déviée
sistema pronto, stilo deflesso
 Palpador preparado; vástago deflexionado

Signalfolge
Signal sequence
Diagramme des signaux
Treno di segnali
Secuencia de la señal

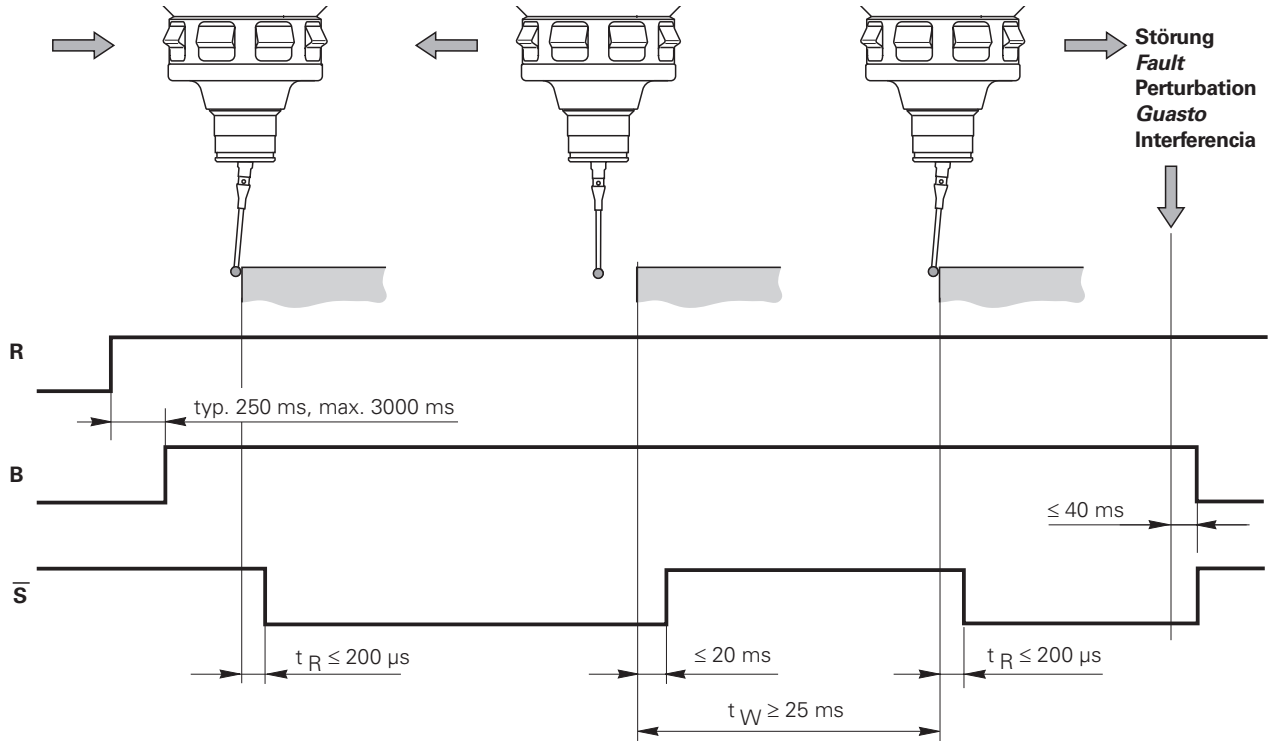

HEIDENHAIN

DR. JOHANNES HEIDENHAIN GmbH

Dr.-Johannes-Heidenhain-Straße 5

83301 Traunreut, Germany

☎ +49 8669 31-0

FAX +49 8669 5061

E-mail: info@heidenhain.de

Technical support FAX +49 8669 32-1000

Measuring systems ☎ +49 8669 31-3104

E-mail: service.ms-support@heidenhain.de

TNC support ☎ +49 8669 31-3101

E-mail: service.nc-support@heidenhain.de

NC programming ☎ +49 8669 31-3103

E-mail: service.nc-pgm@heidenhain.de

PLC programming ☎ +49 8669 31-3102

E-mail: service.plc@heidenhain.de

Lathe controls ☎ +49 8669 31-3105

E-mail: service.lathe-support@heidenhain.de

www.heidenhain.de

