



HEIDENHAIN

Montageanleitung
Mounting Instructions
Instructions de montage
Istruzioni di montaggio
Instrucciones de montaje

TT 140

10/2009

Warnhinweise
Warnings
Recommandations
Avvertenze
Advertencias

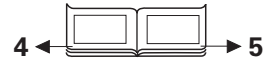

Technische Kennwerte
Specifications
Caractéristiques techniques
Dati tecnici
Datos técnicos



Lieferumfang
Items Supplied
Contenu de la fourniture
Standard di forniture
Elementos suministrados

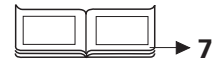

Abmessungen
Dimensions
Dimensions
Dimensioni
Dimensiones

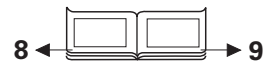

Hinweise zur Montage / Montage
Mounting Procedure / Mounting
Procédure de montage / Montage
Avvertenze per il montaggio / Montaggio
Indicaciones para el montaje / Montaje

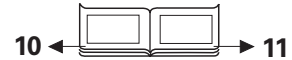

Verbindungsstift / Antastelement wechseln
Exchanging the Connection Pin / Probe Contact
Changer la tige de liaison / l'élément de palpation
Sostituire spina di collegament / elemento di tastatura
Cambiar el vástago de unión / elemento de palpación

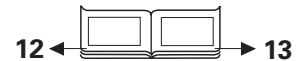

Elektrische Kennwerte
Electrical data
Valeurs électriques
Dati elettrici
Datos eléctricos

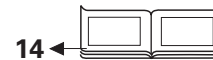

Elektrischer Anschluß
Electrical connection
Raccordement électrique
Collegamento elettrico
Conexión eléctrica





Achtung: Die Montage und Inbetriebnahme ist von einer Fachkraft für Elektrik und Feinmechanik unter Beachtung der örtlichen Sicherheitsvorschriften vorzunehmen.
Die Steckverbindung darf nur spannungsfrei verbunden oder gelöst werden.

Note: *Mounting and commissioning is to be conducted by a specialist in electrical equipment and precision mechanics under compliance with local safety regulations.
Do not engage or disengage any connections while under power.*

Attention: Le montage et la mise en service doivent être réalisés par une personne qualifiée en électricité et mécanique de précision dans le respect des règles de sécurité locales.
Le connecteur ne doit être branché ou débranché que hors tension.

Attenzione: *il montaggio e la messa in funzione devono essere eseguiti da tecnici specialisti elettricisti e in meccanica di precisione nel rispetto delle norme di sicurezza locali.
Il connettore non può essere collegato o scollegato sotto tensione.*

Atención: El montaje y la puesta en marcha deben ser realizados por un especialista en

electricidad y mecánica de precisión, observando las prescripciones locales de seguridad.
Conectar o desconectar el conector sólo en ausencia de tensión.

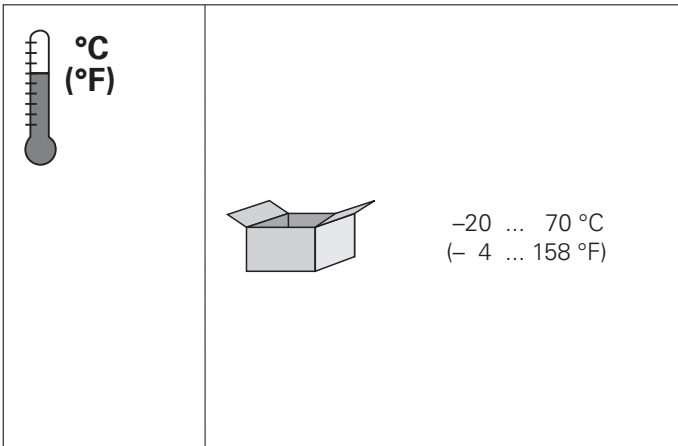
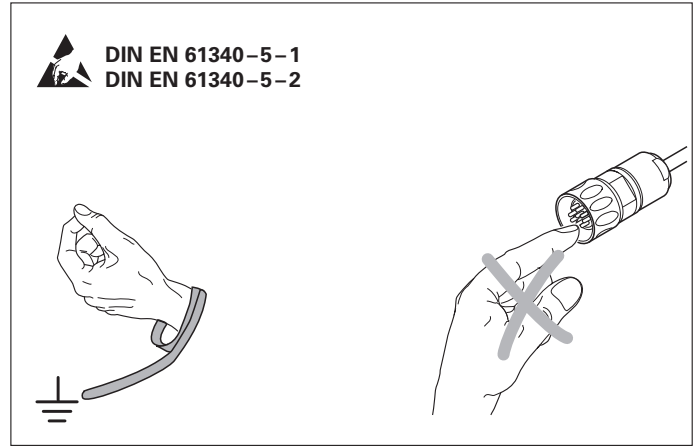
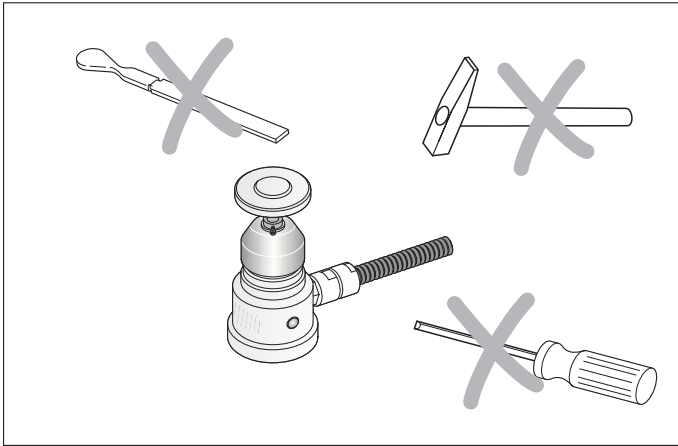

Maße in mm
Dimensions in mm
Cotes en mm
Dimensioni in mm
Dimensiones en mm

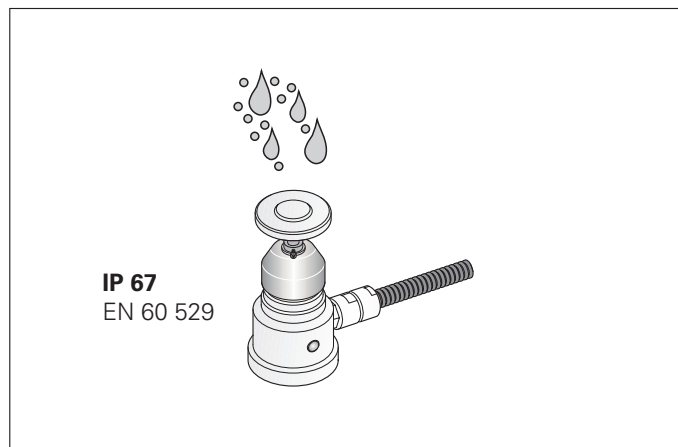
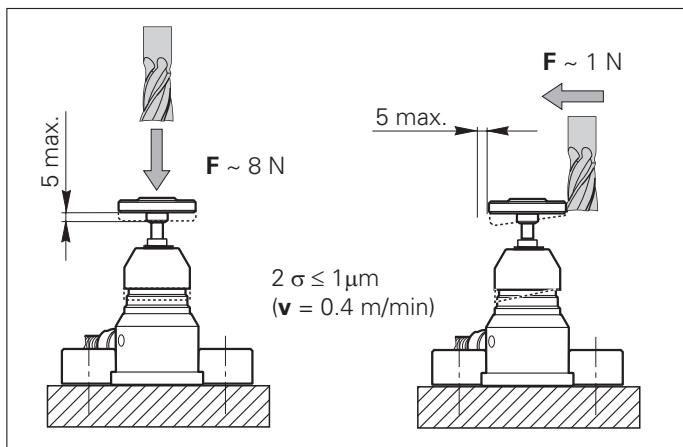

Lieferumfang · Items Supplied · Contenu de la fourniture · Standard di forniture · Elementos suministrados

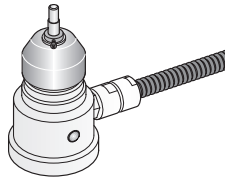
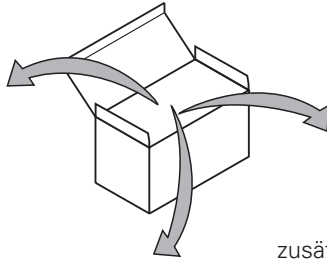
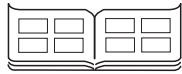

Umfang des Lieferumfanges je nach Variante
Scope of delivery depending on variant
Contenu de la fourniture selon la variante
Standard di forniture a seconda della variante
Elementos suministrados en función de la variante

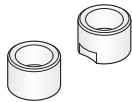

zusätzlicher Verbindungsstift (mit Sollbruchstelle ID 559 758-01)
Additional connection pin (rated break point ID 559 758-01)
 tige de liaison supplémentaire (avec point de rupture ID 559 758-01)
spine di collegamento aggiuntive (con punta di rottura nominale ID 559 758-01)
 vástago de unión adicional (con fusible mecánico ID 559 758-01)

Optionen · Options · Options · Opzioni · Opciones

Antastelement
Probe contact
 Élément de palpéage
Elemento di tastatura
 Elemento de palpación



ID 574 752-01



ID 527 801-01

Ersatzteilkit Stift
Spare parts kit for connection pin
 Kit de rechange tige
Kit di sostituzione spine
 Kit de recambio del vástago



ID 559 758-01

Montagesockel
Connection fixture
 Socle de montage
Dima di montaggio
 Zócalo de montaje

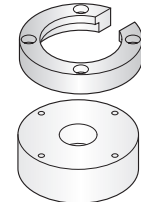

ID 332 400-01

Abmessungen · Dimensions · Dimensions · Dimensioni · Dimensiones

mm



Tolerancing ISO 8015

ISO 2768 - m H

< 6 mm: ±0.2 mm

Befestigung mit Spannpratzen

Mounting with fixing clamps

Fixation avec griffes de serrage

Fissaggio con graffette

Fijación con garras excéntricas

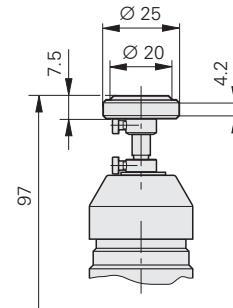
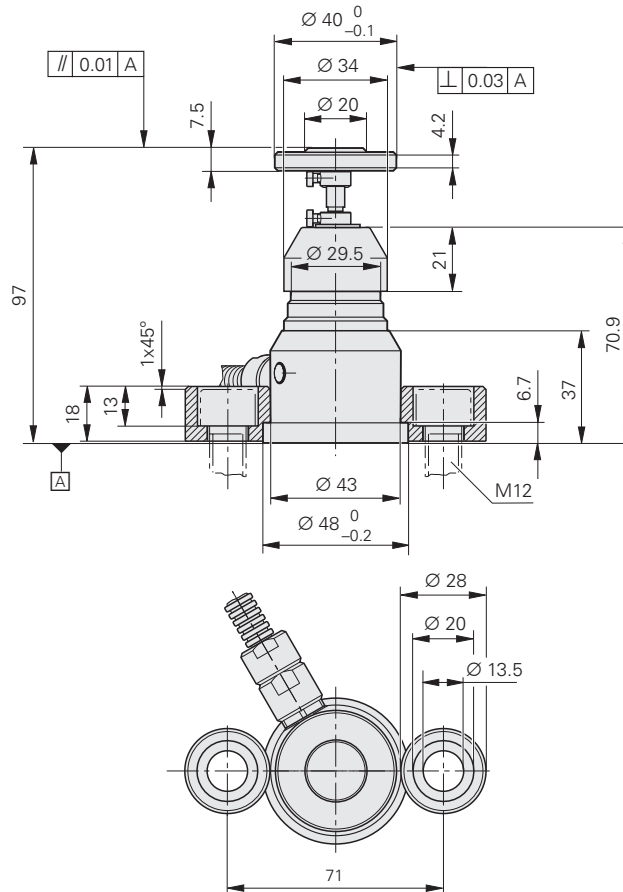

mm



Tolerancing ISO 8015

ISO 2768 - m H

< 6 mm: ± 0.2 mm

Befestigung auf Montagesockel (Zubehör)

Mounting on connection fixture (accessory)

Fixation avec socle de montage (accessoire)

Fissaggio della dima di montaggio (accessorio)

Fijación sobre zócalo de montaje (accessorio)

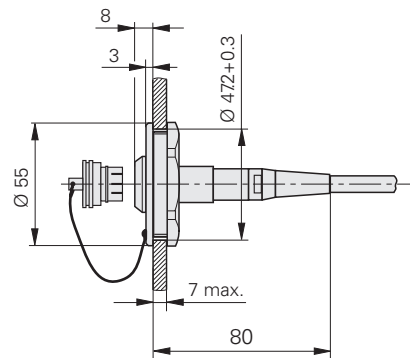
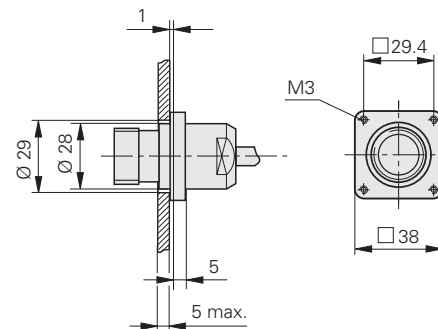
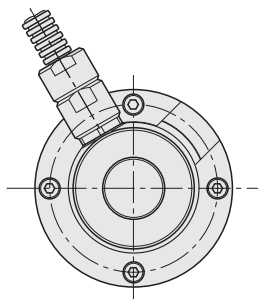
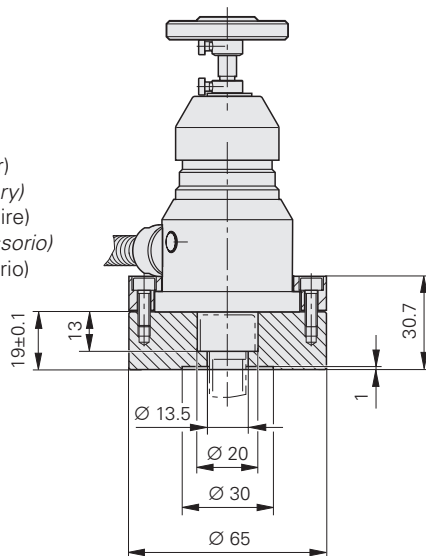

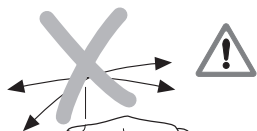
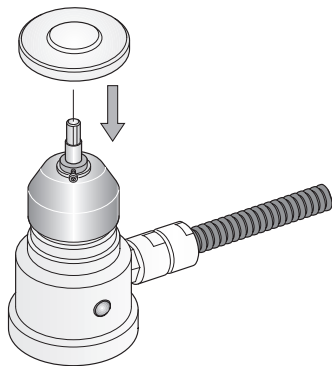

Achtung: Kräfteinwirkung kann Verbindungsstift zerstören

Caution: Too much force can destroy the connection pin

Attention: La force exercée peut détruire la tige de liaison

Attenzione: una forza eccessiva potrebbe rompere lo spine di collegamento

Atención: La aplicación de fuerza puede dañar el vástago de unión

SW2
 $M_d = 1 \text{ Nm}$

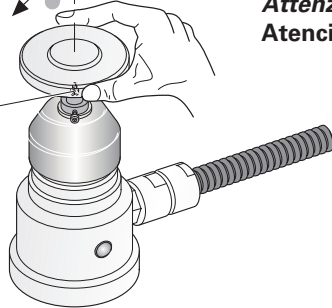

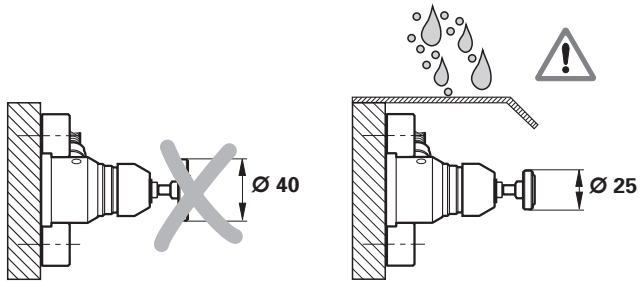

2x
M12 ISO 4762
M_d = 75 Nm

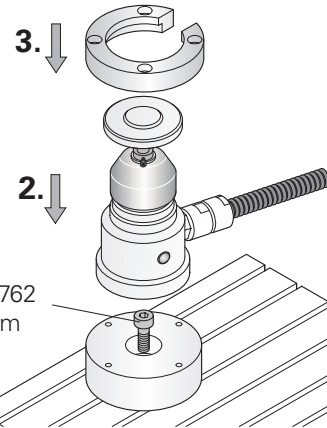
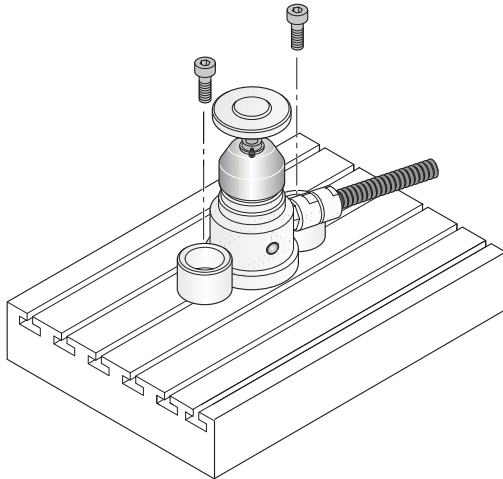

1.
M12 ISO 4762
M_d = 75 Nm

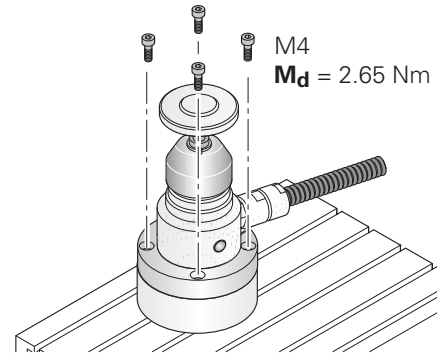

M4
M_d = 2.65 Nm

1.

1x (2x) lösen
Loosen 1 (2) screw(s)
Dévisser 1x (x2)
1x (2x) allentare
Desatornillar 1x (2x)

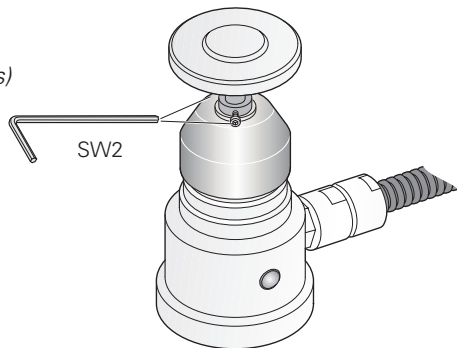

2.

Antastelement entnehmen
Remove the probe contact
Retirer l'élément de palpage
sfilare l'elemento di tastatura
Retirar el elemento de palpación

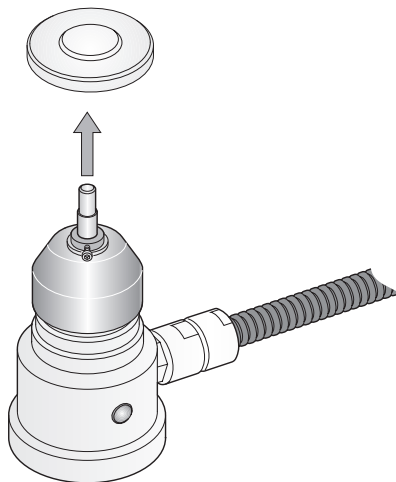

3.

Verbindungsstift auswechseln
Exchange the connection pin
Changer la tige de liaison
sostituire la spina di collegamento
Cambiar el vástago de unión

neue Schraube verwenden (Lieferumfang)
Use a new screw (included in items supplied)
Utiliser une nouvelle vis (dans la fourniture)
utilizzare viti nuove (nello standard di forniture)
utilizar nuevo tornillo (contenido en elementos suministrados)

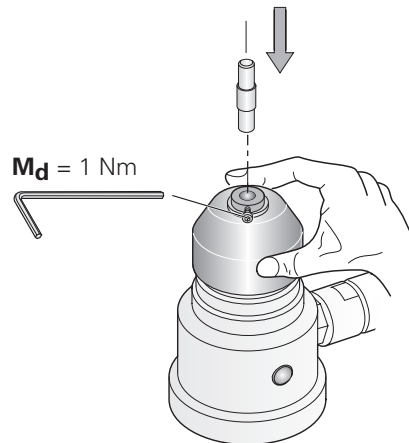

4.

Antastelement befestigen

Secure the probe contact

Fixer l'élément de palpéage

Fissare l'elemento di tastatura

Fijar el elemento de palpación

neue Schraube verwenden (Lieferumfang)

Use a new screw (included in items supplied)

Utiliser une nouvelle vis (dans la fourniture)

utilizzare viti nuove (nello standard di fornitura)

utilizar nuevo tornillo (contenido en elementos suministrados)

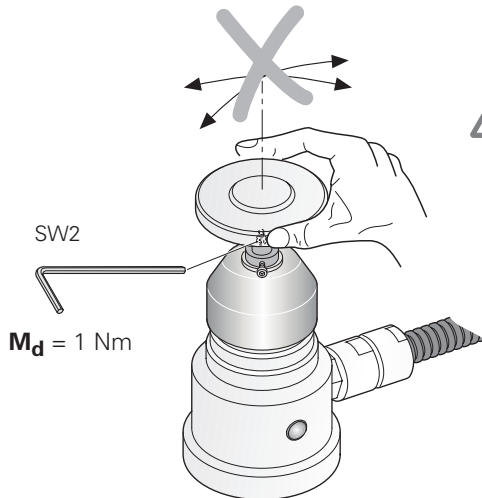

Achtung: Krafteinwirkung kann Verbindungsstift zerstören

Caution: Too much force can destroy the connection pin

Attention: La force exercée peut détruire la tige de liaison

Attenzione: una forza eccessiva potrebbe rompere le spine di collegamento

Atención: La aplicación de fuerza puede dañar el vástago de unión

5.

Tastsystem neu Kalibrieren

Recalibrate the touch probe

Réétalonner le palpeur

Ricalibrare il sistema di tastatura

Volver a calibrar el sistema de palpación

$U_P = 10 \dots 30 \text{ V}$

(max. 100 mA)

EN 50 178

PELV \neq EN 60204-1

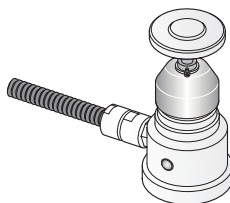

HTL

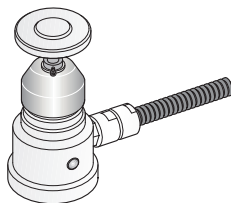

$t \leq 10 \mu\text{s}$

S

\bar{S}

$U_H \geq [U_P - 4 \text{ V}]$
($-I_H \leq 20 \text{ mA}$)

$U_L \leq 2.8 \text{ V}$
($I_L \leq 20 \text{ mA}$)

S, \bar{S} = Schaltsignal
Trigger signal
 Signal de commutation
Segnale di commutazione
 Señal de conexión

Elektrischer Anschluß · Electrical connection · Raccordement électrique · Collegamento elettrico · Conexión eléctrica

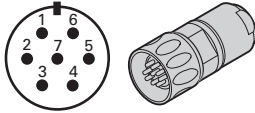

1	2	3	4	5	6	7
U _N	U _P	S	\bar{S}	*		/
WH	BN	GN	YE	/	/	/

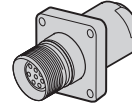
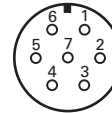

ID 310 194-xx



1	2	3	4	5	6	7
U _N	U _P	S	\bar{S}	/	/	/
WHGN	BNGN	BN	GN	GY	PK	/

* Brücke · Bridge · pont · ponte · puente

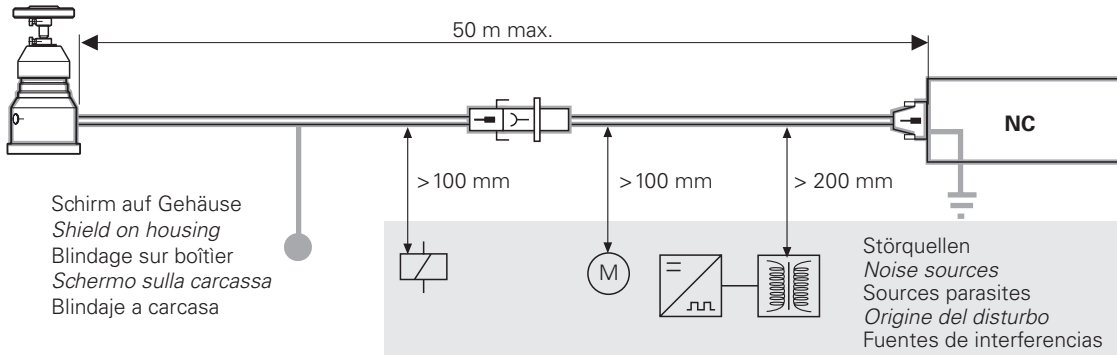

HEIDENHAIN

DR. JOHANNES HEIDENHAIN GmbH

Dr.-Johannes-Heidenhain-Straße 5

83301 Traunreut, Germany

☎ +49 8669 31-0

FAX +49 8669 5061

E-mail: info@heidenhain.de

Technical support FAX +49 8669 32-1000

Measuring systems ☎ +49 8669 31-3104

E-mail: service.ms-support@heidenhain.de

TNC support ☎ +49 8669 31-3101

E-mail: service.nc-support@heidenhain.de

NC programming ☎ +49 8669 31-3103

E-mail: service.nc-pgm@heidenhain.de

PLC programming ☎ +49 8669 31-3102

E-mail: service.plc@heidenhain.de

Lathe controls ☎ +49 8669 31-3105

E-mail: service.lathe-support@heidenhain.de

www.heidenhain.de

