

m&h RADIO-WAVE TOUCH PROBE

RWP20.50-G



Table of Contents

1	Description	55
1.1	General	55
1.1.1	Preface	55
1.1.2	Safety Instructions	55
1.1.3	Validity	55
1.2	Purpose.....	56
1.3	Declarations and Approvals.....	57
1.3.1	Europe (EU Declaration of Conformity)	57
1.3.2	USA (FCC Declaration)	57
1.3.3	Canada (IC /RSS Declaration)	57
1.3.4	China	57
1.3.5	Japan	57
1.4	System Components	58
1.5	Variant Overview	59
1.6	Technical Data.....	60
1.6.1	Technical Data, General (all Measuring Units)	60
1.6.2	Technical Data with Measuring Unit MY21.00	60
1.6.3	Technical Data with Measuring Unit PP41.00	60
1.6.4	Technical Data with Measuring Unit HPP41.10	61
1.6.5	Technical Data with Temperature Measuring Unit TP44.10	61
1.6.6	Technical Data with Ultrasonic Measuring Unit UTP47.10	61
1.7	Dimensions	62
1.7.1	Dimensions with Measuring Unit MY21.00	62
1.7.2	Dimensions with Measuring Unit PP41.00	63
1.7.3	Dimensions with Precision Measuring Unit HPP41.10	64
1.7.4	Dimensions with Temperature Measuring Unit TP44.10	65
1.7.5	Dimensions with Ultrasonic Measuring Unit UTP47.10	66
1.8	Transmission and Reception Area	67
1.9	Activation Methods	68
1.9.1	Activation Method - AZ (patented)	68
1.9.2	Activation Method - WS (patented)	68
1.9.3	Activation Method - ME	68
1.9.4	Activation Method - BI (Bidirectional Activation)	68
1.10	Delivery Contents, Accessories and Spares	69
1.10.1	Explanation of Order Numbers.....	69
1.10.2	Delivery Contents	69
1.10.3	Accessories, General	69
1.10.4	Styli.....	70
1.10.5	Temperature Sensors.....	75
1.10.6	Ultrasonic Probe Heads	76
1.10.7	Shanks.....	77
1.10.8	Pullstuds	79
1.10.9	Spares	81
2	Operation	82
2.1	Tools, Measurement and Test Equipment	82

2.2	Commissioning and Setup of the Touch Probe.....	83
2.2.1	Changing the Temperature Sensor, Stylus or Ultrasonic Probe Head.....	83
2.2.2	Inserting/Changing the Battery.....	86
2.2.3	Setting the Activation Method and Interference Safety / Pairing the Touch Probe with a Receiver.....	87
2.2.4	Aligning Stylus to Spindle Centre.....	91
2.3	Optical Status Display	92
2.4	Replacing Measuring Unit (PP41.00, HPP41.10, MY21.00 and TP44.10).....	93
2.5	Replacing Measuring Unit (UTP47.10).....	94
2.6	Adjusting Trigger Force (Measuring Unit PP41.00 only).....	95
2.7	Maintenance and Cleaning (Measuring Unit PP41.00, HPP41.10 only)	96
2.8	Measuring the temperature with temperature measuring unit TP44.10	97
2.8.1	Temperature Measurement Process	97
2.8.2	Temperature Measurement: Example Applications.....	98
2.9	Ultrasonic measurement with ultrasonic measuring unit UTP47.10	99
2.10	Probe Extension	100
2.11	Modular System (for Measuring Units PP41.00 and MY21.00 only)	101

1 Description

1.1 General

1.1.1 Preface

The safety instructions in this manual have to be strictly observed to guarantee a safe and reliable function of the touch probe and to avoid personal and material damage. The meaning of the symbols related to the safety instructions is described in the table below:

NOTICE	NOTICE indicates important information that, if not observed, could lead to property damage/malfunctions.
INFORMATION	INFORMATION indicates important information or helpful advices for the work with the described device.

1.1.2 Safety Instructions

NOTICE
<p>Risk of material damage!</p> <ul style="list-style-type: none"> Manual or automatic positioning of the touch probe must be protected, in a way that the machine axis stops feeding if the probe is triggered outside the measuring process!

NOTICE
<p>Risk of material damage!</p> <ul style="list-style-type: none"> Feedhold or spindle-stop resulting from a trigger or ready signal from a touch probe should only happen if the probe is actually in the spindle. This safety logic prevents the spindle or feed being stopped during normal milling operations if a signal from a measuring probe is triggered for one of the following reasons: <ul style="list-style-type: none"> Battery replacement and subsequent functional check of the touch probe by manually switching it on. Another machine with a radio-wave touch probe installed is started up and this touch probe transmits on the same channel as a touch probe previously installed.

NOTICE
<p>Risk of material damage caused by third-party parts!</p> <ul style="list-style-type: none"> Only use the original spare parts listed in these operating instructions to perform maintenance and repairs.

INFORMATION
<p>The information given in this manual can be changed by the manufacturer at any time. Thus the user is responsible to regularly inquire about updated information.</p>

1.1.3 Validity

These operating instructions are valid for the hardware available at the date of creation of these operating instructions. The manufacturer reserves the right to make technical modifications.

1.2 Purpose

The radio-wave touch probe IRP20.50-G is used for workpiece measurement, and automatic determination and compensation of deviating angular positions of workpieces. Moreover, it is used for setting zero points inside the machine tool.

The radio-wave touch probe RWP20.50-G is capable of measuring workpiece geometries, like edges, bores, bosses, slots, webs, angles, corners and circular arches. It is also suitable for measuring complex geometries, like three-dimensional surfaces and for measurements involving picot axes.

In addition, the radio-wave touch probe RWP20.50-G can be used for measuring temperatures on workpiece surfaces and for the ultrasonic measurement of workpiece thicknesses.

Radio-wave transmission ensures that the measuring signals from the touch probe can be transmitted to the receiver over large distances.

1.3 Declarations and Approvals

1.3.1 Europe (EU Declaration of Conformity)

The EU Declaration of Conformity can be found at the end of these operating instructions.

If required, a copy of the signed original declaration of conformity may be requested from the address given on the back cover.

1.3.2 USA (FCC Declaration)

This device complies with Part 15 of the FCC. Operation is subject to the following two conditions:

- (1) This device may not cause harmful interference, and
- (2) This device must accept any interference received, including interference that may cause undesired operation.

This device has been tested and found to comply with the limits for a Class A digital device, pursuant to Part 15 of the FCC Rules. These limits are designed to provide reasonable protection against harmful interference when the device is operated in a commercial environment. This device generates, uses, and can radiate radio frequency energy and, if not installed and used in accordance with the instruction manual, may cause harmful interference to radio communications. Operation of this device in a residential area is likely to cause harmful interference in which case the user will be required to correct the interference at his own expense.

The radiated output power of the device is far below the FCC radio frequency exposure limits. Nevertheless, the device shall be used in such a manner that the potential for human contact during normal operation is minimized.

Changes or modifications not expressly approved by m&h Inprocess Messtechnik GmbH may void the FCC/RSS authorization to operate this equipment.

FCC ID: MFFRWP2050G1

1.3.3 Canada (IC /RSS Declaration)

English:

This device complies with Industry Canada licence-exempt RSS standard(s).

Operation is subject to the following two conditions:

- (1) This device may not cause harmful interference, and
- (2) This device must accept any interference received, including interference that may cause undesired operation.

Français:

Le présent appareil est conforme aux CNR d'Industrie Canada applicables aux appareils radio exempts de licence. L'exploitation est autorisée aux deux conditions suivantes:

- (1) l'appareil ne doit pas produire de brouillage, et
- (2) l'appareil doit accepter tout brouillage radioélectrique subi, même si le brouillage est susceptible d'en compromettre le fonctionnement.

IC: 5782A-RWP2050G1

1.3.4 China

This device has an RTA certificate (Radio Transmission Equipment Type Approval Certificate) issued by the SRRC (State Radio Regulatory Committee) for use in China.

CMIT ID: 2016DJ1391

1.3.5 Japan

This device has a certificate issued by the Japanese MIC (Ministry of Internal Affairs and Communications) for use in Japan. This certification complies with the Japanese Radio Law:

㊦ R2-SME003

1.4 System Components

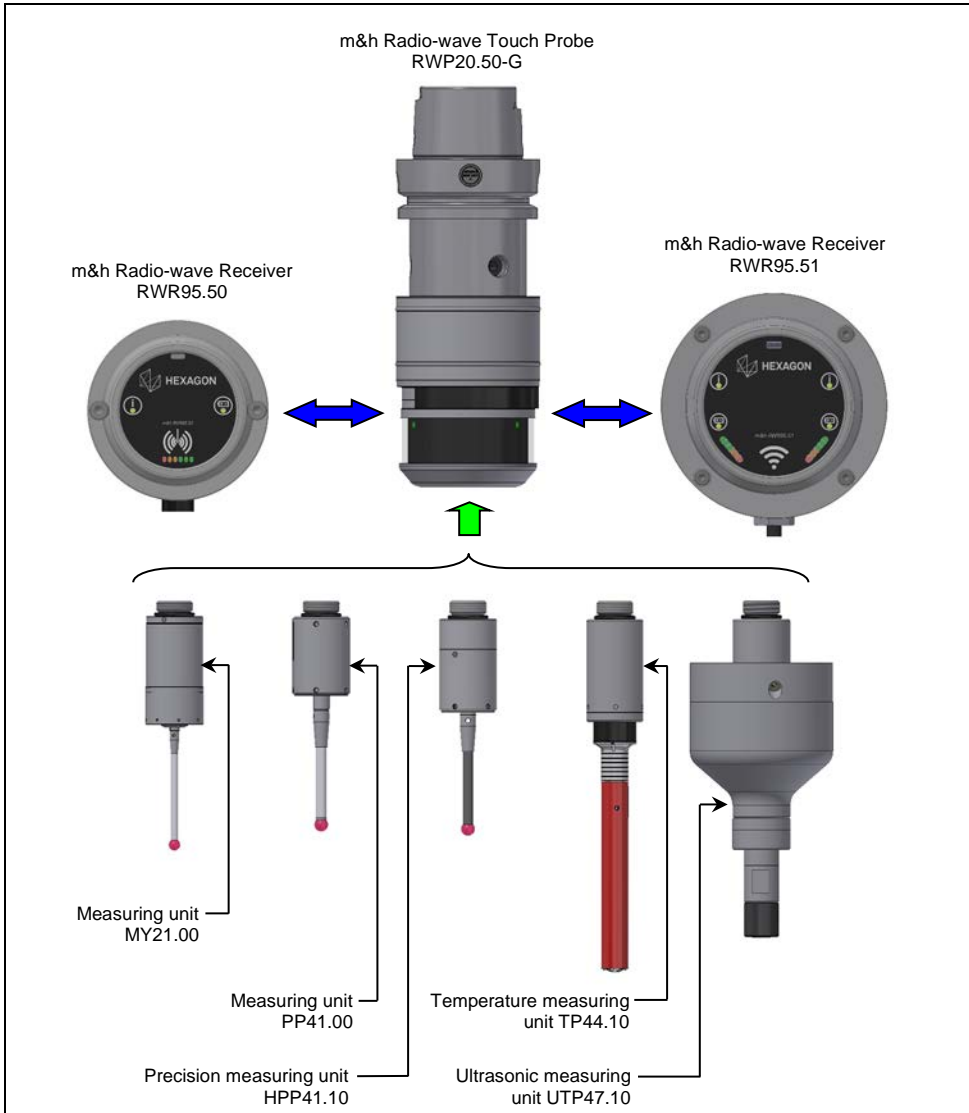







Fig. 1 System Components

INFORMATION

Ultrasonic measurement is only possible in conjunction with radio-wave receiver RWR95.51.
This function is not supported when using m&h radio-wave receiver RWR95.50.

1.5 Variant Overview

RWP20.50-G-MY	RWP20.50-G-PP	RWP20.50-G-HPP	RWP20.50-G-TP	RWP20.50-G-UTP
Measuring unit MY21.00	Measuring unit PP41.00	Precision measuring unit HPP41.10	Temperature measuring unit TP44.10	Ultrasonic measuring unit UTP47.10
				

1.6 Technical Data

1.6.1 Technical Data, General (all Measuring Units)

Transmission frequency	2400-2483.5 MHz (2.4 GHz)
Transmission/reception range	Up to 18 m
Power supply	1x 9 V battery, block, 6LR61, Lithium: 1200 mAh, Alkaline: 550 mAh
Material	Stainless steel, POM
Temperature range	Operation: 10°C - 50°C, Storage: 5°C - 70°C
Sealing	IP68: EN60529

1.6.2 Technical Data with Measuring Unit MY21.00

Sensing Directions	$\pm X$; $\pm Y$; $-Z$
Maximum Stylus Overtravel	$XY = \pm 14^\circ$; $Z = -4.5$ mm
Trigger Force with 50 mm Stylus	$XY = 1$ N $Z = 6$ N
Recommended Probing Feedrate	max. 2000 mm/min
Unidirectional Repeatability (deflection from one direction)	max. 1 μ m (2 Sigma) with 50 mm stylus and 254 mm/min probing feedrate
Weight of RWP20.50-G-MY without Shank	approx. 980 g
Maximum Battery Life with Lithium Battery	Operation: 500 h Standby: 1 year

1.6.3 Technical Data with Measuring Unit PP41.00

Sensing Directions	$\pm X$; $\pm Y$; $-Z$
Maximum Stylus Overtravel	$XY = \pm 12.5^\circ$; $Z = -6$ mm
Trigger Force with 50 mm Stylus	$XY = 0.3 - 1.4$ N (factory setting = 1 N) $Z = 2.5 - 12.5$ N (factory setting = 8.5 N)
Recommended Probing Feedrate	max. 2000 mm/min
Unidirectional Repeatability (deflection from one direction)	max. 1 μ m (2 Sigma) with 50 mm stylus and 254 mm/min probing feedrate
Weight of RWP20.50-G-PP without Shank	approx. 940 g
Maximum Battery Life with Lithium Battery	Operation: 500 h Standby: 1 year

1.6.4 Technical Data with Measuring Unit HPP41.10

Sensing Directions	±X; ±Y; -Z
Maximum Stylus Overtravel	XY = ±12.5°; Z = -5 mm
Tripping force* with 50 mm stylus	XY = 0.1 N (typical value) Z = 2.5 N (typical value)
Trigger force* with 50 mm stylus (probing feedrate 254 mm/min)	XY = 0.75 ±0.25 N Z = 7 N ±10%
Recommended Probing Feedrate	100 - 500 mm/min
Maximum Probing Feedrate	1000 mm/min
Unidirectional Repeatability (deflection from one direction)	max. 0.25 µm (2 Sigma) with 50 mm stylus and 254 mm/min probing feedrate
Weight of RWP20.50-G-HPP without Shank	approx. 940 g
Maximum Battery Life with Lithium Battery	Operation: 180 h Standby: 1 year
<p>* Tripping force = Force when the probing signal is tripped at the touch point not influenced by the machine dynamics (stops without delay when the touch point is reached) Trigger force = Force after passing the touch point influenced by the machine dynamics (positioning speed, delay)</p>	

1.6.5 Technical Data with Temperature Measuring Unit TP44.10

Sensing Directions	-Z
Maximum Stylus Overtravel	-6.9 mm
Trigger Force	13 N
Recommended Probing Feedrate	500 mm/min
Measuring accuracy	±1°C
Resolution	0.1°C
Weight of RWP20.50-G-TP without Shank	approx. 930 g
Maximum Battery Life with Lithium Battery	Operation: 440 h Standby: 1 year

1.6.6 Technical Data with Ultrasonic Measuring Unit UTP47.10

Transmission pulse voltage V_{50}	-70 V ±10% to 50 Ω
Pulse rise time t_r	2 to 5 ns
Pulse fall time t_f	2 to 5 ns
Pulse length t_d	100 ±5 ns
Effective output impedance	8 Ω ±20%
Equivalent input impedance	50 Ω ±18%
Nominal frequency range	1.0 to 30 MHz (-3 dB)
Measurement or pulse repetition frequency	500 Hz
Sensing Directions	-Z
Maximum Stylus Overtravel	-6 mm
Trigger Force	10 N
Recommended Probing Feedrate	500 mm/min
Repeatability (Z)	max.5 µm (2 Sigma)
Measuring accuracy*	±10 µm (at 47.00-UTP-D-0.7/9)
Measuring Range	0.7 - 9 mm (at 47.00-UTP-D-0.7/9)
Weight of RWP20.50-G-UTP without Shank	approx. 1400 g
Maximum Battery Life with Lithium Battery at 5% Probing	Operation: 200 h Standby: 1 year
<p>* The measuring accuracy depends on the condition (surface finish, surface parallelism) and calibration of the workpiece.</p>	

1.7 Dimensions

1.7.1 Dimensions with Measuring Unit MY21.00

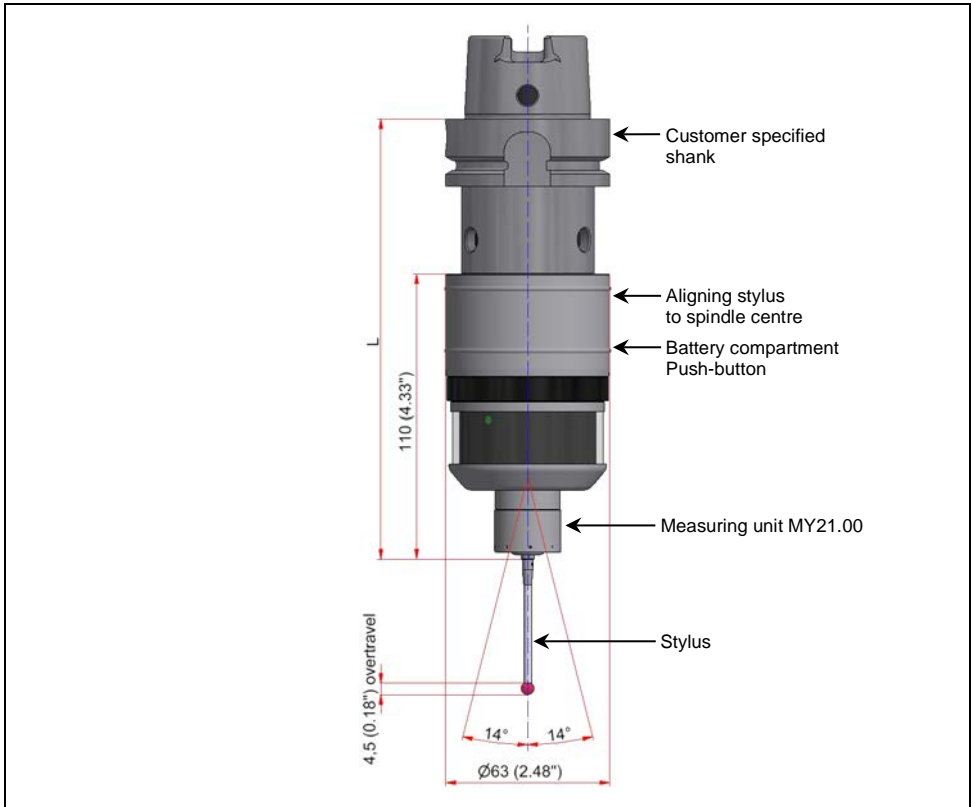

Fig. 2 Dimensions with Measuring Unit MY21.00

1.7.2 Dimensions with Measuring Unit PP41.00

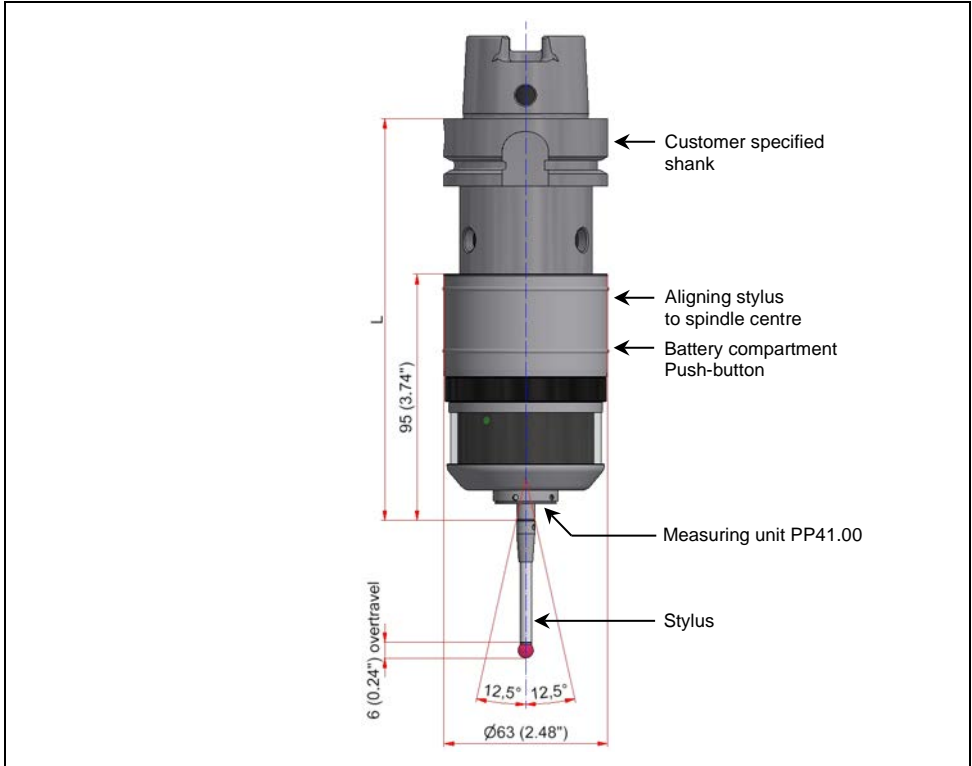

Fig. 3 Dimensions with Measuring Unit PP41.00

1.7.3 Dimensions with Precision Measuring Unit HPP41.10

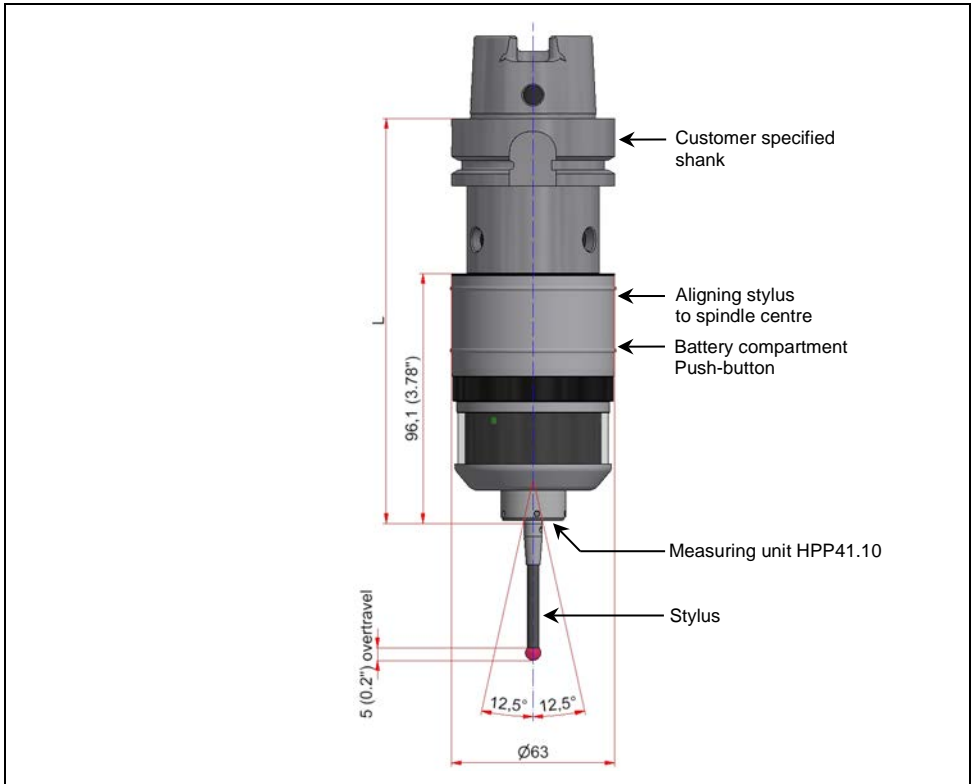

Fig. 4 Dimensions with Measuring Unit HPP41.10

1.7.4 Dimensions with Temperature Measuring Unit TP44.10

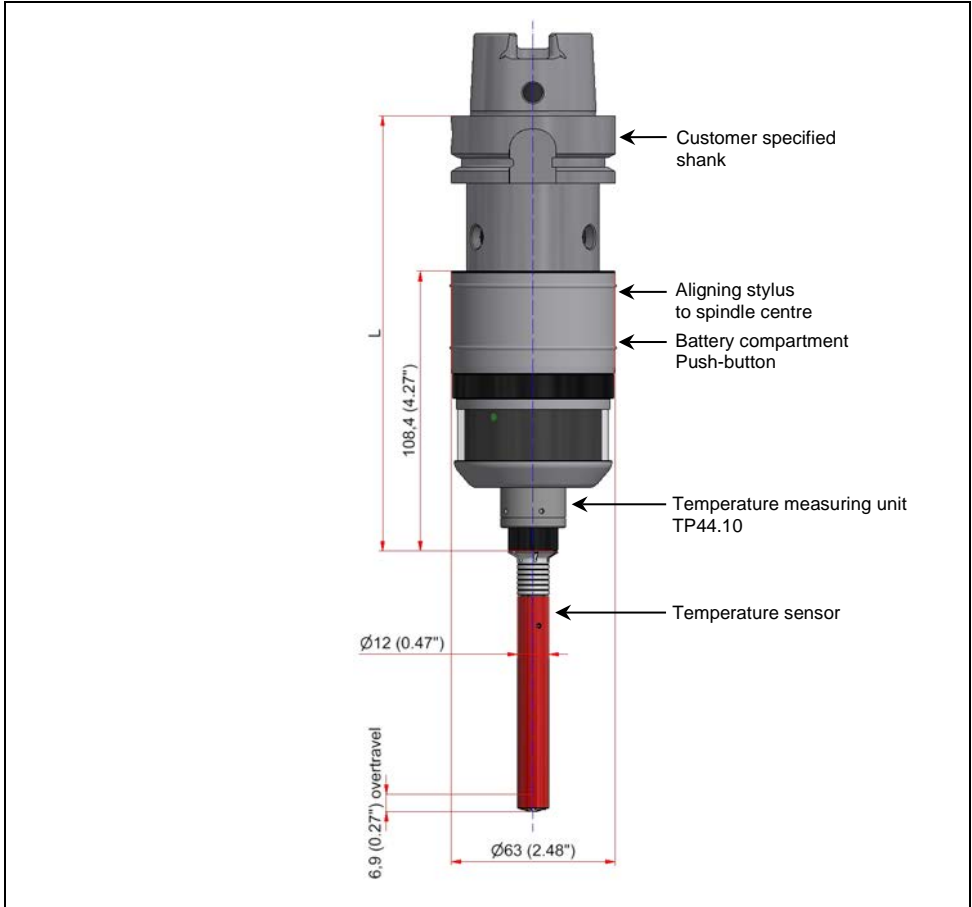

Fig. 5 Dimensions with Temperature Measuring Unit TP44.10

1.7.5 Dimensions with Ultrasonic Measuring Unit UTP47.10

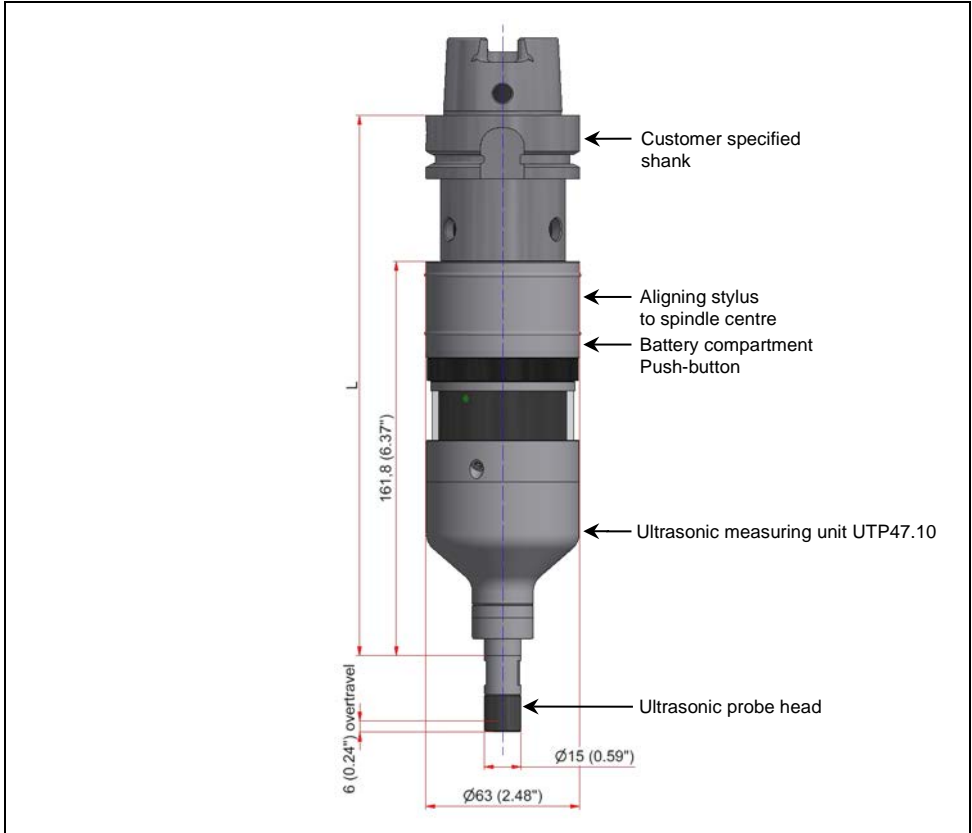

Fig. 6 Dimensions with Ultrasonic Measuring Unit UTP47.10

1.8 Transmission and Reception Area

INFORMATION

The transmission/reception ranges shown below only apply under optimum operating conditions. For a secure signal transmission probe and receiver must be located in the transmission area of the other device. The range for a secure signal transmission is up to 18 m.

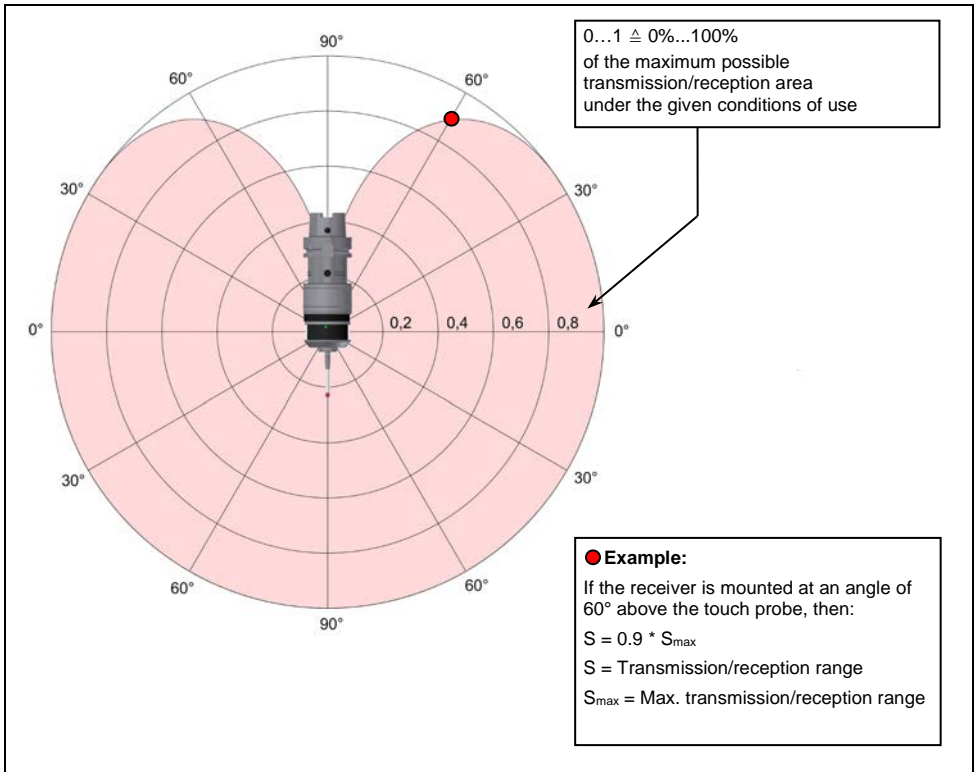

Fig. 7 Transmission and reception area (emission/reception behaviour of antenna)

1.9 Activation Methods

For activation of the radio-wave touch probe RWP20.50-G there are four different methods (see Fig. 8). These methods are described in the subsequent chapters.

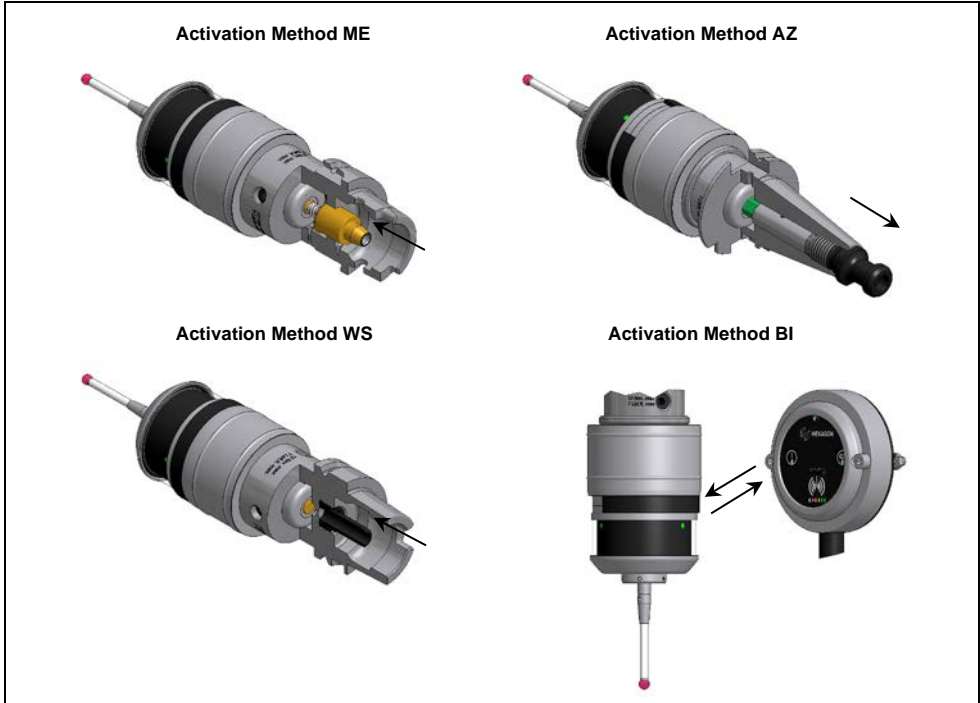

Fig. 8 Overview of activation methods (stylus not included in the delivery contents)

1.9.1 Activation Method - AZ (patented)

Activation method AZ is a mechanical activation method. If the shank is equipped with a pullstud, the probe is activated via tension on the pullstud (refer to Fig. 8).

1.9.2 Activation Method - WS (patented)

Activation method WS can be applied to all machines with programmable through-spindle coolant or switchable air blast > 3.5 bar. The touch probe is activated by programmed switching on of the medium by the M code. The probe is active while under pressure (refer to Fig. 8).

1.9.3 Activation Method - ME

Activation method ME is a mechanical activation method. The probe is activated by a mechanical switch inside the HSK. If the probe is on inside the spindle, the probe is off inside the magazine (refer to Fig. 8).

1.9.4 Activation Method - BI (Bidirectional Activation)

In the case of the activation method BI, the probe is directly activated via a radio-wave signal sent from the receiver.

1.10 Delivery Contents, Accessories and Spares

1.10.1 Explanation of Order Numbers

The order numbers for different touch probe configurations can be broken down as follows:

20.50-G	-	PP	-	SK40	-	06-VCE	-	AZ
Touch probe		Measuring Unit		Shank		Pullstud for activation method		Activation Method
						AZ		
20.50-G G=2.4 GHz		MY = MY21.00 PP = PP41.00 HPP = HPP41.10 TP = TP44.10 UTP = UTP47.10		Chapter 1.10.7		Chapter 1.10.8		Chapter 1.9







INFORMATION









A complete order number must contain at least the number of the touch probe and the description of the measuring unit (e.g. 20.50-G-MY).

1.10.2 Delivery Contents

Order Number	Description
20.50-G-MM	Radio-wave Touch Probe RWP20.50-G
MM = Measuring unit	1x Battery (9 V, 1200 mAh, Lithium) (5677)
	Tool box (25.50-TB)

1.10.3 Accessories, General

Order Number	Description	Illustration
41.00-PP	Measuring unit PP41.00	
41.10-HPP	Precision measuring unit HPP41.10	
21.00-MY	Measuring unit MY21.00	
44.10-TP	Temperature measuring unit TP44.10	
47.10-UTP-XX# (XX=Ultrasonic probe head type, e.g. 47.10-UTP-D-0.7/9# with ultrasonic probe head 47.00-D-0.7/9)	Ultrasonic measuring unit UTP47.10	
41.00-KA	Cross adapter	

Order Number	Description	Illustration
41.00-KA-V	Screw plug for cross adapter	
21.00-VE30	Extension (L=30 mm/1.18")	
21.00-VE50	Extension (L=50 mm/1.97")	
41.00-VE100	Extension (L=100 mm/3.94")	
41.00-VE200	Extension (L=200 mm/7.87")	
91.00-V50	Probe extension (L=50 mm/1.97")	
91.00-V75	Probe extension (L=75 mm/2.96")	
91.00-V100	Probe extension (L=100 mm/3.94")	

1.10.4 Styli





INFORMATION

Only use carbon fiber styli with a maximum length of 103 mm when using precision measuring unit HPP41.10.



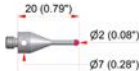

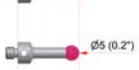
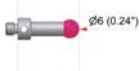
INFORMATION

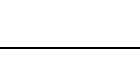
- PP41.00/HPP41.10 = connecting thread M4
- MY21.00 = connecting thread M3

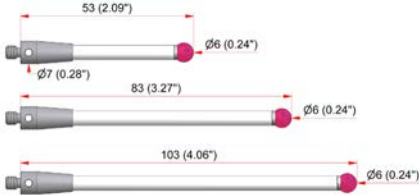
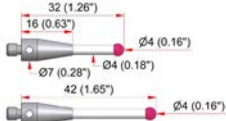

M4 styli with shaft Ø7, steel

Order Number	Illustration
91.00-T20/2-ST-M4-D7 (stainless steel shaft, ruby ball)	
91.00-T20/3-ST-M4-D7 (stainless steel shaft, ruby ball)	
91.00-T20/4-ST-M4-D7 (stainless steel shaft, ruby ball)	
91.00-T20/5-ST-M4-D7 (stainless steel shaft, ruby ball)	
91.00-T20/6-ST-M4-D7 (stainless steel shaft, ruby ball)	
91.00-T20/8-ST-M4-D7 (stainless steel shaft, ruby ball)	

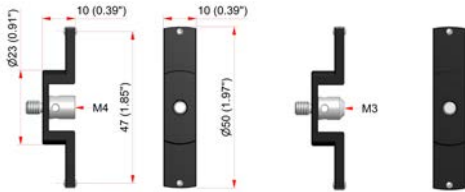

M4 styli with shaft Ø7, ceramic

Order Number	Illustration
91.00-T53/6-KE-M4 (ceramic shaft, ruby ball)	
91.00-T83/6-KE-M4 (ceramic shaft, ruby ball)	
91.00-T103/6-KE-M4 (ceramic shaft, ruby ball)	
91.00-T32/4-KE-M4 (ceramic shaft, ruby ball)	
91.00-T42/4-KE-M4 (ceramic shaft, ruby ball)	
91.00-T42.5/5-KE-M4 (ceramic shaft, ruby ball)	
91.00-T42.5/5-KE-M4 (ceramic shaft, ruby ball)	
91.00-T52.5/5-KE-M4 (ceramic shaft, ruby ball)	
91.00-T52.5/5-KE-M4 (ceramic shaft, ruby ball)	
91.00-T62.5/5-KE-M4 (ceramic shaft, ruby ball)	
91.00-TS-ST-M4 91.00-TS-ST-M4/M3 (disc-stylus, steel, Ø50 mm)	

M4 styli with shaft Ø7, carbon fiber

Order Number	Illustration
91.00-T53/6-CA-M4 (carbon fiber shaft, ruby ball)	
91.00-T103/6-CA-M4 (carbon fiber shaft, ruby ball)	

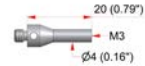
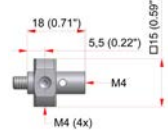
Accessories for M4 styli

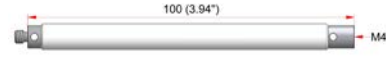
Order Number	Illustration
91.00-S-M4/M4 (stylus adapter)	
91.00-TA-M4/M3 (stylus adapter)	
91.00-TK-ST-M4 (5-way cross probe)	
91.00-TV30-KE-M4 (stylus extension, ceramic)	
91.00-TV50-KE-M4 (stylus extension, ceramic)	
91.00-TV100-KE-M4 (stylus extension, ceramic)	

Ball Disc Stylus M4

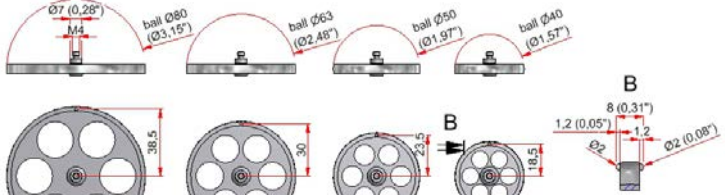
Order Number	Illustration
91.00-TS80-ST-M4 91.00-TS63-ST-M4 91.00-TS50-ST-M4 91.00-TS40-ST-M4	





M4 clamping adapter

Order Number	Illustration
<p>41.00-KM-M4 (clamped to shaft $\varnothing 7$, with cap head screw AF2 mm, radially adjustable)</p>	



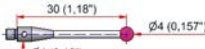

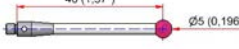

M3 styli with shaft $\varnothing 4$, tungsten carbide

Order Number	Illustration
21.00-T20/1-HM-M3 (tungsten carbide shaft, ruby ball)	
21.00-T20/2-HM-M3 (tungsten carbide shaft, ruby ball)	
21.00-T20/3-HM-M3 (tungsten carbide shaft, ruby ball)	
21.00-T20/4-HM-M3 (tungsten carbide shaft, ruby ball)	
21.00-T20/5-HM-M3 (tungsten carbide shaft, ruby ball)	
21.00-T20/6-HM-M3 (tungsten carbide shaft, ruby ball)	
21.00-T30/2-HM-M3 (tungsten carbide shaft, ruby ball)	
21.00-T30/3-HM-M3 (tungsten carbide shaft, ruby ball)	
21.00-T30/4-HM-M3 (tungsten carbide shaft, ruby ball)	
21.00-T30/5-HM-M3 (tungsten carbide shaft, ruby ball)	
21.00-T30/6-HM-M3 (tungsten carbide shaft, ruby ball)	
21.00-T40/2-HM-M3 (tungsten carbide shaft, ruby ball)	
21.00-T40/3-HM-M3 (tungsten carbide shaft, ruby ball)	

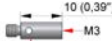
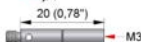
M3 styli with shaft Ø4, ceramic

Order Number	Illustration
21.00-T30/4-KE-M3 (ceramic shaft, ruby ball)	
21.00-T40/4-KE-M3 (ceramic shaft, ruby ball)	
21.00-T40/5-KE-M3 (ceramic shaft, ruby ball)	
21.00-T50/5-KE-M3 (ceramic shaft, ruby ball)	
21.00-T60/5-KE-M3 (ceramic shaft, ruby ball)	

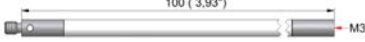
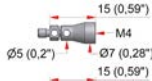
Accessories for M3 styli

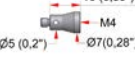
Order Number	Illustration
21.00-TV10-ST-M3 (stylus extension, stainless steel)	
21.00-TV20-ST-M3 (stylus extension, stainless steel)	
21.00-TV30-ST-M3 (stylus extension, stainless steel)	
21.00-TV40-ST-M3 (stylus extension, stainless steel)	
21.00-TV40-KE-M3 (stylus extension, ceramic)	
21.00-TV60-KE-M3 (stylus extension, ceramic)	
21.00-TV100-KE-M3 (stylus extension, ceramic)	
91.00-S-M3/M4 (break shaft adapter)	
21.00-S-M3/M3 (break shaft adapter)	
21.00-S-M3 (stylus adapter)	
91.00-TA-M3/M4 (stylus adapter)	

1.10.5 Temperature Sensors

Order Number	Illustration
44.00-T50 (temperature sensor) (L=50 mm/1.97")	
44.00-T100 (temperature sensor) (L=100 mm/3.94")	
44.00-T150 (temperature sensor) (L=150 mm/5.91")	

INFORMATION

A calibration table is provided for every temperature sensor, which shows its deviation from the m&h reference measurement device. In order to achieve an accuracy level of within $\pm 1^\circ\text{C}$, the measurement values taken with the temperature sensor must be calculated using the corresponding correction values!

The achievable resolution is:

- $\pm 0.1^\circ\text{C}$ => for analog/digital machine inputs
- $\pm 1^\circ\text{C}$ => for analog/analog machine inputs

Calibration Table:

Temperature Workpiece	Correction Sensor Temperature
5,0°C	0,2°C
6,0°C	0,2°C
7,0°C	0,2°C
8,0°C	0,2°C
9,0°C	0,2°C
10,0°C	0,2°C
11,0°C	0,3°C
12,0°C	0,3°C
13,0°C	0,3°C
14,0°C	0,3°C
15,0°C	0,3°C
16,0°C	0,3°C
17,0°C	0,3°C
18,0°C	0,3°C
19,0°C	0,3°C
20,0°C	0,3°C
21,0°C	0,3°C
22,0°C	0,3°C
23,0°C	0,3°C
24,0°C	0,3°C
25,0°C	0,3°C
26,0°C	0,3°C
27,0°C	0,3°C
28,0°C	0,3°C
29,0°C	0,3°C
30,0°C	0,3°C
31,0°C	0,3°C
32,0°C	0,3°C
33,0°C	0,3°C
34,0°C	0,3°C
35,0°C	0,3°C
36,0°C	0,3°C
37,0°C	0,3°C
38,0°C	0,3°C
39,0°C	0,3°C
40,0°C	0,3°C
41,0°C	0,3°C
42,0°C	0,3°C
43,0°C	0,1°C
44,0°C	0,1°C
45,0°C	0,1°C
46,0°C	0,1°C
47,0°C	0,1°C
48,0°C	0°C
49,0°C	0°C
50,0°C	0°C

Deviation of displayed temperature according to nominal value:

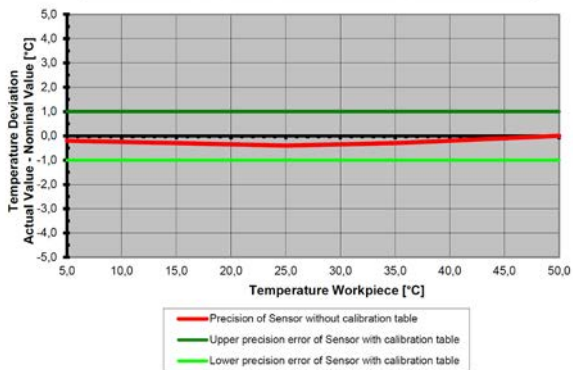



Fig. 9 Temperature sensor calibration table

1.10.6 Ultrasonic Probe Heads

Order Number	Illustration
47.00-D-0.7/9 (ultrasonic probe head) (L=28 mm/1.1")	 The illustration shows a cylindrical ultrasonic probe head. It has a black body with a silver-colored front section. Dimension lines indicate a length of 28 mm (1.10 inches) and a diameter of 15 mm (0.59 inches).

1.10.7 Shanks

NOTICE

Risk of collision caused by incorrect input of probe length

The touch probe length specified in the subsequent tables is only valid for measuring unit PP41.00. For the additional available measuring units the following values have to be added:

- MY21.00 (15 mm or 0.59")
- HPP41.10 (1.1 mm or 0.04")
- TP44.10 (13.3 mm or 0.52")

Shanks for activation method AZ

Possible shanks	Activation pulling force	Length L (Fig. 3) with PP41.00	Order Number (MM = Measuring unit, XX=AZ type, refer to 1.10.8)
DIN69871-SK30	315 N	133 mm (5.24")	20.50-G-MM-SK30-XX-AZ
DIN69871-SK40	830 N	135 mm (5.31")	20.50-G-MM-SK40-XX-AZ
DIN69871-SK50	760 N	135 mm (5.31")	20.50-G-MM-SK50-XX-AZ
DIN2080-SK50	760 N	131 mm (5.16")	20.50-G-MM-DIN2080-SK50-XX-AZ
DIN69871-SK60	-	155 mm (6.10")	20.50-G-MM-SK60-XX-AZ
BT40	830 N	135 mm (5.31")	20.50-G-MM-BT40-XX-AZ
BT50	760 N	150 mm (5.90")	20.50-G-MM-BT50-XX-AZ
CAT40	830 N	135 mm (5.31")	20.50-G-MM-AN40-XX-AZ
CAT50	760 N	135 mm (5.31")	20.50-G-MM-AN50-XX-AZ
Nikken-NC5-46	-	154 mm (6.06")	20.50-G-MM-NC5-46-AZ
Nikken-NC5-63	-	154 mm (6.06")	20.50-G-MM-NC5-63-AZ
Other shanks	-		Upon request

Shanks for activation method WS

Possible shanks	Activation pressure (Coolant/Spindle air)	Length L (Fig. 3) with PP41.00	Order Number (MM = Measuring unit)
DIN69871-SK30	3.5 bar (50 psi) - 50 bar (725 psi)	133 mm (5.24")	20.50-G-MM-SK30-WS
DIN69871-SK30-	3.5 bar (50 psi) - 50 bar (725 psi)	133 mm (5.24")	20.50-G-MM-SK30-MUBEA-WS
DIN69871-SK40	3.5 bar (50 psi) - 50 bar (725 psi)	135 mm (5.31")	20.50-G-MM-SK40-WS
DIN69871-SK50	3.5 bar (50 psi) - 50 bar (725 psi)	135 mm (5.31")	20.50-G-MM-SK50-WS
DIN2080-SK50	3.5 bar (50 psi) - 50 bar (725 psi)	131 mm (5.16")	20.50-G-MM-DIN2080-SK50-
DIN69871-SK60	3.5 bar (50 psi) - 50 bar (725 psi)	155 mm (6.10")	20.50-G-MM-SK60-WS
BT30	3.5 bar (50 psi) - 50 bar (725 psi)	133 mm (5.24")	20.50-G-MM-BT30-WS
BT40	3.5 bar (50 psi) - 50 bar (725 psi)	135 mm (5.31")	20.50-G-MM-BT40-WS
BT50	3.5 bar (50 psi) - 50 bar (725 psi)	150 mm (5.91")	20.50-G-MM-BT50-WS
CAT40	3.5 bar (50 psi) - 50 bar (725 psi)	135 mm (5.31")	20.50-G-MM-AN40-WS
CAT50	3.5 bar (50 psi) - 50 bar (725 psi)	135 mm (5.31")	20.50-G-MM-AN50-WS
DIN69893-HSK-A63	3.5 bar (50 psi) - 50 bar (725 psi)	155 mm (6.10")	20.50-G-MM-HSK63A-WS
DIN69893-HSK-F63	3.5 bar (50 psi) - 50 bar (725 psi)	160 mm (6.30")	20.50-G-MM-HSK63F-WS
DIN69893-HSK-A80	3.5 bar (50 psi) - 50 bar (725 psi)	160 mm (6.30")	20.50-G-MM-HSK80A-WS
DIN69893-HSK-A100	3.5 bar (50 psi) - 50 bar (725 psi)	160 mm (6.30")	20.50-G-MM-HSK100A-WS
Coromant Capto C5	3.5 bar (50 psi) - 50 bar (725 psi)	160 mm (6.30")	20.50-G-MM-C5-WS
Coromant Capto C6	3.5 bar (50 psi) - 50 bar (725 psi)	160 mm (6.30")	20.50-G-MM-C6-WS
Coromant Capto C8	3.5 bar (50 psi) - 50 bar (725 psi)	160 mm (6.30")	20.50-G-MM-C8-WS
Nikken-NC5-46	3.5 bar (50 psi) - 50 bar (725 psi)	154 mm (6.06")	20.50-G-MM-NC5-46-WS
Nikken-NC5-63	3.5 bar (50 psi) - 50 bar (725 psi)	154 mm (6.06")	20.50-G-MM-NC5-63-WS
Kennametal KM63	3.5 bar (50 psi) - 50 bar (725 psi)	160 mm (6.30")	20.50-G-MM-KM63-WS
Kennametal KM80	3.5 bar (50 psi) - 50 bar (725 psi)	160 mm (6.30")	20.50-G-MM-KM80-WS
D28-VDI40-W	3.5 bar (50 psi) - 50 bar (725 psi)	137 mm (5.39")	20.50-G-MM-VDI40-WS
D28-VDI50-W	3.5 bar (50 psi) - 50 bar (725 psi)	137 mm (5.39")	20.50-G-MM-VDI50-WS
D28-VDI60-W	3.5 bar (50 psi) - 50 bar (725 psi)	137 mm (5.39")	20.50-G-MM-VDI60-WS
D28-VDI80-W	3.5 bar (50 psi) - 50 bar (725 psi)	137 mm (5.39")	20.50-G-MM-VDI80-WS
Other shanks	-		Upon request

Shanks for activation method ME

Possible shanks	Activation force	Length L (Fig. 3) with PP41.00	Order Number (MM = Measuring unit)
DIN69893-HSK-A50	30 N	155 mm (6.10")	20.50-G-MM-HSK-50A-ME
DIN69893-HSK-A63	30 N	155 mm (6.10")	20.50-G-MM-HSK-63A-ME
DIN69893-HSK-A80	30 N	160 mm (6.30")	20.50-G-MM-HSK-80A-ME
DIN69893-HSK-A100	30 N	160 mm (6.30")	20.50-G-MM-HSK-100A-ME
DIN69893-HSK-E50	30 N	155 mm (6.10")	20.50-G-MM-HSK-50E-ME
DIN69893-HSK-E63	30 N	155 mm (6.10")	20.50-G-MM-HSK-63E-ME
<i>Other shanks</i>	-		<i>Upon request</i>

Shanks for activation method BI











Possible shanks	Length L (Fig. 3) with PP41.00	Order Number (MM = Measuring unit)
DIN69871-SK30	133 mm (5.24")	20.50-G-MM-SK30
DIN69871-SK30-MUBEA	133 mm (5.24")	20.50-G-MM-SK30-MUBEA
DIN69871-SK40	135 mm (5.31")	20.50-G-MM-SK40
DIN69871-SK50	135 mm (5.31")	20.50-G-MM-SK50
DIN2080-SK50	131 mm (5.16")	20.50-G-MM-DIN2080-SK50
DIN69871-SK60	155 mm (6.10")	20.50-G-MM-SK60
BT30	133 mm (5.24")	20.50-G-MM-BT30
BT40	135 mm (5.31")	20.50-G-MM-BT40
BT50	150 mm (5.91")	20.50-G-MM-BT50
CAT40	135 mm (5.31")	20.50-G-MM-AN40
CAT50	135 mm (5.31")	20.50-G-MM-AN50
DIN69893-HSK-A50	155 mm (6.10")	20.50-G-MM-HSK50A
DIN69893-HSK-E50	155 mm (6.10")	20.50-G-MM-HSK50E
DIN69893-HSK-A63	155 mm (6.10")	20.50-G-MM-HSK63A
DIN69893-HSK-E63	155 mm (6.10")	20.50-G-MM-HSK-63E
DIN69893-HSK-F63	160 mm (6.30")	20.50-G-MM-HSK63F
DIN69893-HSK-A80	160 mm (6.30")	20.50-G-MM-HSK80A
DIN69893-HSK-A100	160 mm (6.30")	20.50-G-MM-HSK100A
Coromant Capto C5	160 mm (6.30")	20.50-G-MM-C5
Coromant Capto C6	160 mm (6.30")	20.50-G-MM-C6
Coromant Capto C8	160 mm (6.30")	20.50-G-MM-C8
Nikken-NC5-46	154 mm (6.06")	20.50-G-MM-NC5-46
Nikken-NC5-63	154 mm (6.06")	20.50-G-MM-NC5-63
Kennametal KM63	160 mm (6.30")	20.50-G-MM-KM63
Kennametal KM80	160 mm (6.30")	20.50-G-MM-KM80
D28-VDI40-W	137 mm (5.39")	20.50-G-MM-VDI40
D28-VDI50-W	137 mm (5.39")	20.50-G-MM-VDI50
D28-VDI60-W	137 mm (5.39")	20.50-G-MM-VDI60
D28-VDI80-W	137 mm (5.39")	20.50-G-MM-VDI80
<i>Other shanks</i>	<i>Upon request</i>	

1.10.8 Pullstuds

Order no.	AZ-01	AZ-02	AZ-22	AZ-04/17
AZ type (XX)	01	02	22	04/17
Type	DIN69872-13 for SK30	DIN69872-19 for SK40/CAT40	DIN69872-19 for BT40 (+3 mm)	ISO 7388/2 Type B for SK40/CAT40
Illustration				
Order no.	AZ-04+3MM	AZ-06	AZ-06-3MM	AZ-06-VCE
AZ type (XX)	04+3	06	06-3	06-VCE
Type	ISO 7388/2 Type B for BT40 (+3 mm)	JIS B 6339 Type 1 for BT40	JIS B 6339-Type 1 for SK40/CAT40 (-3 mm)	Special for SK40/CAT 40
Illustration				
Order no.	AZ-07	AZ-07-3MM	AZ-08	AZ-08-3MM
AZ type (XX)	07	07-3	08	08-3
Type	JIS B 6339 Type 2 for BT40	JIS B 6339 Type 2 for SK40/CAT40 (-3 mm)	JIS B 6339 Type 3 for BT40	JIS B 6339 Type 3 for SK40/CAT40 (-3 mm)
Illustration				







Order no.	AZ-03	AZ-05/19	AZ-03+25MM	AZ-TOS KURIM
AZ type (XX)	03	05/19	03+25	TOS KURIM
Type	DIN69872-28 for SK50	ISO 7388/2 Type B for SK50/CAT50	DIN69872-28 for SK50 (+25 mm)	for SK50
Illustration				
Order no.	AZ-13	AZ-14	AZ-15	AZ-SK60
AZ type (XX)	13	14	15	SK60
Type	JIS B 6339 Type 1 for BT50	JIS B 6339 Type 2 for BT50	JIS B 6339 Type 3 for BT50	DIN69872-40 for SK60
Illustration				

1.10.9 Spares

Order Number	Description	Illustration
5677	Battery (9 V, 1200 mAh, Lithium)	
5525	Snap ring	
1477	O-ring 53.5x1.2 Viton	
0506	Clamping screw	
1352	Adjustment screw DIN913 M4x8 (AF2 mm)	
3240	Service cover	
3455	O-ring 16x1 Viton for service cover	
2906	Metal eyelid	
2931	Conical spring	
2074	O-ring 24x2 Viton	
0857	O-ring 26x2 Viton	

2 Operation

2.1 Tools, Measurement and Test Equipment

Order Number	Description	Illustration
0227	Hexagon key AF1.3 mm	
1097	Hexagon key AF2 mm	
1665	Spanner AF4 mm	
0885	Mounting pin	
2951	C-spanner	
3079	Dial gauge	
25.50-TB	Tool box, consisting of: 1x Battery (9 V, 1200 mAh, lithium) (5677) 4x Adjustment screw DIN913, M4x8, AF2 mm (1352) 1x Mounting pin (0885) 1x Spanner AF4 mm (1665) 2x C-Spanner (2951) 2x Hexagon key AF2 mm (1097) 1x Hexagon key AF1.3 mm (0227)	Not illustrated

2.2 Commissioning and Setup of the Touch Probe

2.2.1 Changing the Temperature Sensor, Stylus or Ultrasonic Probe Head

2.2.1.1 Installing/Changing the Temperature Sensor (Temperature Measuring Unit TP44.10)

NOTICE

Risk of damage to the equipment!

- Clean and dry the probe well!
- Do not use compressed air to clean the touch probe!
- Do not touch the sensor tip!

1. **Solely** hold the white base of the socket and pull carefully.
2. Press sensor completely into the socket and pay attention to the orientation of the contact plugs.

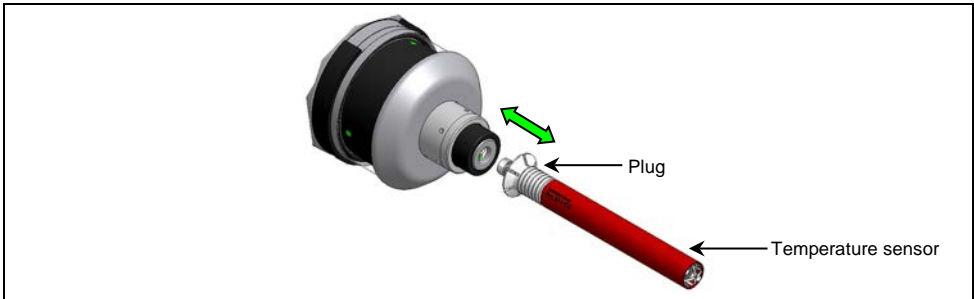

Fig. 10 Sensor change with temperature measuring unit TP44.10

2.2.1.2 Installing/Changing the Stylus (Measuring Unit MY21.00)

NOTICE

Risk of damage to the equipment!

- Do not apply any turning force to the measuring unit!
- During replacement, always hold the stylus connection with the spanner AF4 mm!

1. Unscrew the stylus from the touch probe using the mounting pin.
2. Carefully screw the new stylus with mounting pin into the touch probe (Fig. 11).
3. Align the stylus to spindle center (refer to chapter 2.2.4).
4. Calibrate the touch probe.



Fig. 11 Stylus change with measuring unit MY21.00

2.2.1.3 Installing/changing the stylus (Measuring Unit PP41.00/HPP41.10)

NOTICE

Risk of damage to the equipment!

The probe mechanic is sensitive, therefore never use excessive force when screwing in the stylus!

- The screwing torque is $M=2\text{ Nm}$!
- When using a break shaft adapter (91.00-S-M4/M4), only screw in the stylus with a maximal torque of 1 Nm (0.74 lbf.ft)!
- The use of a break shaft adapter (91.00-S-M4/M4) is not permitted in conjunction with precision measuring unit HPP41.10!

1. Unscrew the stylus from the touch probe using the mounting pin.
2. Carefully screw the new stylus with mounting pin into the touch probe (Fig. 12).
3. Align the stylus to spindle center (refer to chapter 2.2.4).
4. Calibrate the probe.

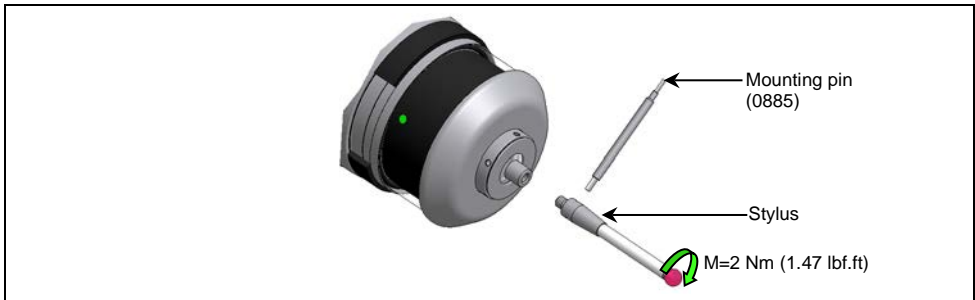

Fig. 12 Stylus change with measuring unit PP41.00

2.2.1.4 Installing/Changing the Ultrasonic Probe Head (Ultrasonic Measuring Unit UTP47.10)

1. **Carefully** unscrew the ultrasonic probe head with an AF13 mm spanner and slowly pull out the connecting cable slightly.
2. Loosen the plug by gently pulling on the surface of the ultrasonic probe head.
3. Attach the plug to the new ultrasonic probe head.
4. **Carefully** screw in the ultrasonic probe head until it stops and tighten gently with an AF13 mm spanner.

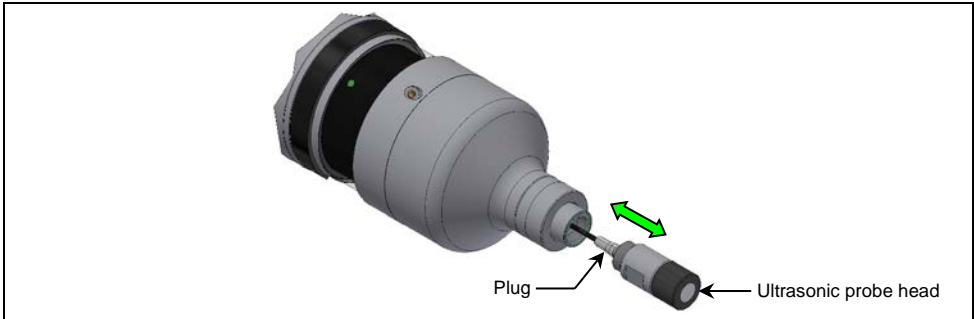

Fig. 13 Probe head change with ultrasonic measuring unit UTP47.10

INFORMATION

The ultrasonic measuring unit and ultrasonic probe head form one unit and are perfectly coordinated. An ultrasonic probe head can only be replaced with another probe head of the same type.

2.2.2 Inserting/Changing the Battery

NOTICE

Risk of damage to the equipment!

- Clean and dry the probe well before opening!
- Do not use compressed air to clean the touch probe!
- Replace empty battery immediately!

1. Laterally pull the snap ring off from the probe (1./Fig. 14).
2. Carefully slide the battery compartment sleeve down (2./Fig. 14).

INFORMATION

The Touch Probe RWP20.50-G is protected against wrong polarity. Therefore there is no need to pay attention to the polarity when inserting a new battery!

3. Take the used battery out of the battery compartment and insert a new battery (3./Fig. 14).

NOTICE

Risk of damage to the equipment!

- When closing the battery compartment, ensure the O-ring is properly seated!

4. Carefully slide the battery compartment sleeve upwards (4./Fig. 14).
5. Position the snap ring at the probe laterally and slide it over the probe (5./Fig. 14).

INFORMATION

After changing the battery, the time for starting the touch probe (reboot) is approx. 5 s!

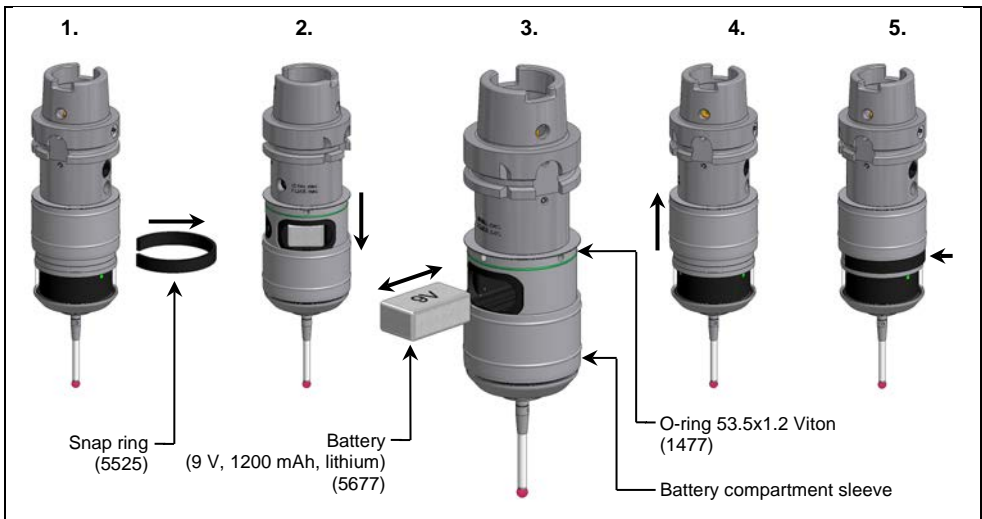

Fig. 14 Battery replacement

2.2.3 Setting the Activation Method and Interference Safety / Pairing the Touch Probe with a Receiver

2.2.3.1 Menu Structure

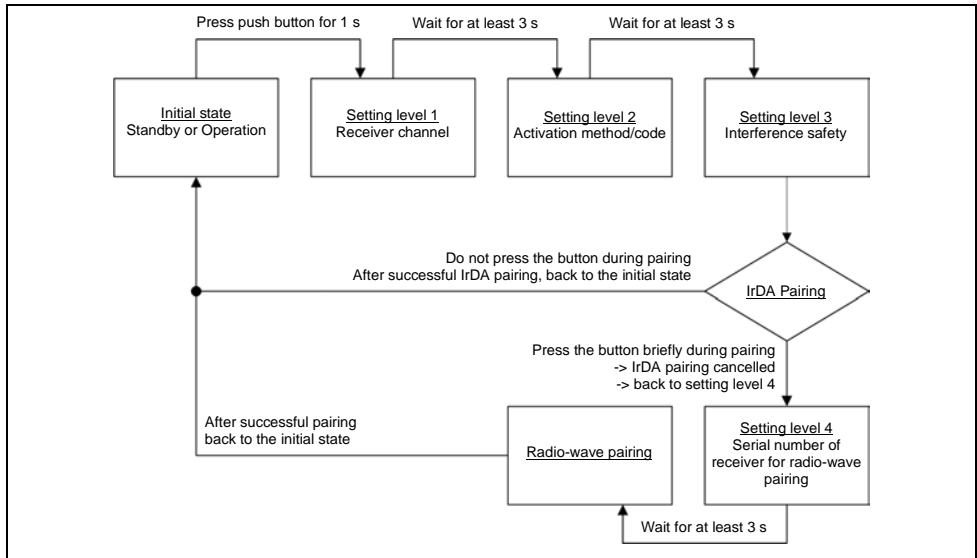

Fig. 15 Menu structure

Additional explanations of the setting levels:

Setting level 1	
Receiver channel for pairing	
1	Channel 1
2	Channel 2

Setting level 2		
	Activation	Activation code
X ₀	AZ	-
X ₁	WS/ME	-
X _A	BI	A
X _B	BI	B
X _C	BI	C
⋮	⋮	⋮
X _H	BI	H
X-	Delete*	

X = Set channel number (1/2) from Level 1

* Deletes the touch probe pairing from the receiver memory

Setting level 3	
Interference safety	
0.0.	Fast
0.1.	Normal
0.2.	Secure (Trigger Evaluation 2 ms)
0.3.	Secure (Trigger Evaluation 10 ms)
0.4.	Secure (Trigger Evaluation 20 ms)

Setting level 4	
Serial number of receiver	
1.X	1st digit of serial number
2.X	2nd digit of serial number
3.X	3rd digit of serial number
4.X	4th digit of serial number
5.X	5th digit of serial number

X = 0-9

2.2.3.2 Possible Settings

The following table shows the settings available in each level of the touch probe menu. In conjunction with m&h radio-wave receiver RWR95.50, only the settings with a grey background can be used. All settings are available when using RWR95.51.

Level 1	Level 2		Level 3	IrDA Pairing	Level 4		Radio-wave pairing	Successful
Channel	Activation method/code		Interference safety		Serial number of receiver			
	Channel 1	Channel 2			Digit 1	Digit 5		
1	10	20	00		10 ... 50	11		
2	11	21	01		11 ... 51			
	1A	2A	02		12 ... 52			
	1B	2B	03					
	1C	2C	04		19 ... 59			
	10	20						
	1E	2E						
	1F	2F						
	1G	2G						
	1H	2H						
	1-	2-						

2.2.3.3 Setting Procedure

NOTICE

Risk of damage to the equipment!

- Clean and dry the probe well before opening!
- Do not use compressed air to clean the touch probe!

1. Slide the battery compartment sleeve partially down, keeping the battery held in place in the touch probe.
2. Press the button for approx. 1 s to display the channel set.

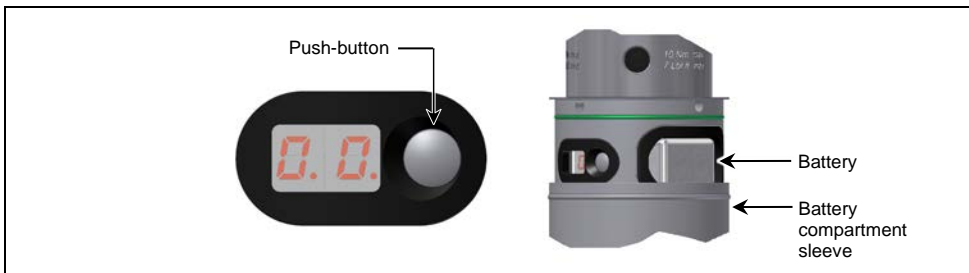

Fig. 16 Entering the settings

3. Keep pressing the push-button to set the desired channel (setting level 1).
 - ▶ After approx. 3 s, the display automatically jumps to setting the activation method.
4. Keep pressing the push-button to set the activation method and activation code (setting level 2).
 - ▶ After approx. 3 s, the display automatically jumps to the setting of the interference safety.

NOTICE

Risk of measuring deviations!

- The touch probe needs to be urgently recalibrated to avoid measuring deviations after the interference safety setting has been changed!

5. Press the push-button to set the interference safety (setting level 3).
 - ▶ If the button is not pressed again, after approx. 3 s the display shows two alternately flashing squares. The touch probe is now in Pairing mode for **pairing via the integrated IrDA interface** and can be paired with a receiver. To do this, hold the IR interface of the touch probe directly in front of the IR interface on the receiver (refer to Fig. 17). The recipient must be in "Standby" operation, i.e., the power supply to the receiver must be present, but no activation signal from the control and no "Ready" signal from a previously paired touch probe must be transmitted to the receiver. After successful pairing, both LEDs briefly illuminate green on the receiver and the display on the touch probe now shows two squares blinking simultaneously for approx. 5 s.
 - ▶ If the button is pressed again, the display automatically jumps to **Pairing via radio-wave** (see also Fig. 15, setting level 4).

6. Keep pressing the push-button to enter each digit of the serial number of the receiver to be paired. If the button is not pressed again, the display automatically jumps to the next digit. 5 digits need to be entered in total (setting level 4).
 - ▶ After entering the serial number of the receiver to be paired, pairing takes place via radio-wave. The recipient must be in "Standby" operation, i.e., the power supply to the receiver must be present, but no activation signal from the control and no "Ready" signal from a previously paired touch probe must be transmitted to the receiver. After successful pairing, both LEDs briefly illuminate green on the receiver and the display on the touch probe now shows two squares blinking simultaneously for approx. 5 s.

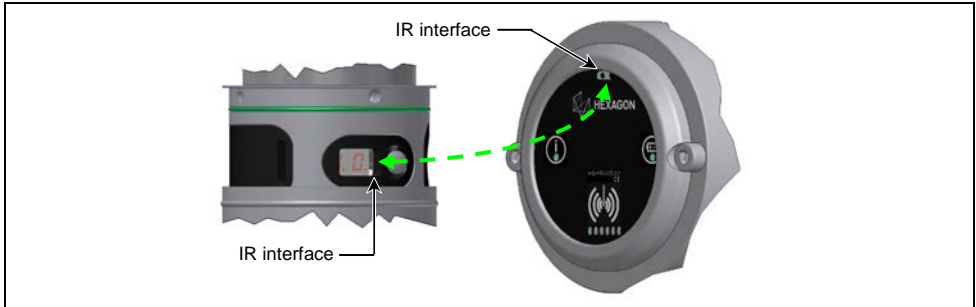

Fig. 17 **Pairing**

7. Close the battery compartment sleeve.

NOTICE

Risk of damage to the equipment!

- When closing the battery compartment, ensure the O-ring is properly seated!

2.2.4 Aligning Stylus to Spindle Centre

NOTICE

Risk of damage to the equipment!

- Clean and dry the probe well!
- Do not use compressed air to clean the touch probe!

1. Remove the snap ring from the side of the probe.
2. Slide battery compartment sleeve downward.
3. Adjust the probe with the adjustment screws A (4x) to within less than $5\ \mu\text{m}$ (Fig. 18).
4. Tighten the adjustment screws A (4x) against each other (Fig. 18).
5. Slide the battery compartment sleeve back up again and push the snap ring back on.
6. Check the alignment of the stylus.
7. Calibrate the probe.

NOTICE

Risk of damage to the equipment!

- When closing the battery compartment sleeve, make sure the O-ring is properly seated!

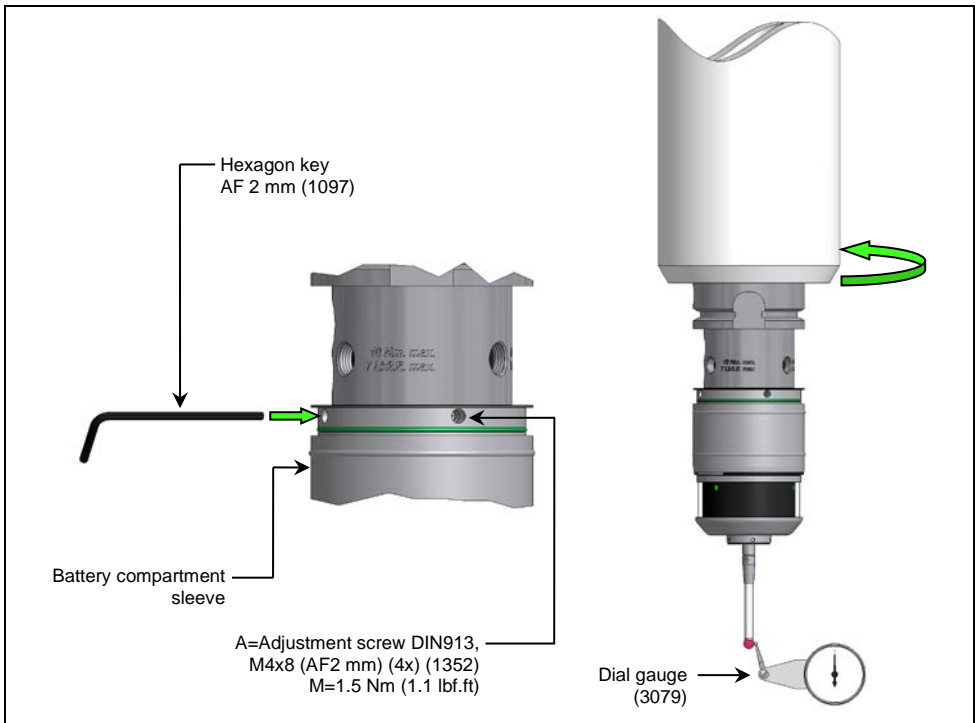

Fig. 18 Aligning stylus to spindle centre

2.3 Optical Status Display

The table below gives an overview of the blinking patterns of the LEDs (Fig. 19) and their meaning.

LEDs blinking green	Touch probe is transmitting signals
LEDs blinking green/red	LOW BATTERY
LEDs blinking orange	Stylus deflected
LEDs permanently red	Error
LEDs permanently red (for 5 s after battery is inserted)	Temperature measuring unit inserted
LEDs permanently blue (for 5 s after battery is inserted)	Mechanical measuring unit inserted
LEDs permanently green (for 5 s after battery is inserted)	Precision measuring unit inserted
LEDs permanently purple (for 5 s after battery is inserted)	Ultrasonic measuring unit inserted
LEDs blinking blue	Activation attempt with no paired receiver within range



Fig. 19 Optical Status Display

2.4 Replacing Measuring Unit (PP41.00, HPP41.10, MY21.00 and TP44.10)

NOTICE

Risk of damage to the equipment!

- Clean and dry the probe well before opening!
- Do not use compressed air to clean the touch probe!
- When inserting the new measuring unit, ensure that the O-rings inside the touch probe housing and on the measuring unit are properly seated!

1. Remove the stylus or the temperature sensor respectively according to chapter 2.2.1.
2. Remove the battery from the touch probe according to chapter 2.2.2.
3. Insert the C-spanner into the bores of the measuring unit and carefully unscrew the measuring unit in a counter-clockwise direction.
4. Insert the new measuring unit into the touch probe and carefully screw it in by hand.
5. Insert the C-spanner into the bores of the new measuring unit, screw the measuring unit completely to the stop.
6. Mount the stylus or the temperature sensor respectively according to chapter 2.2.1.
7. Reinsert the battery into the touch probe according to chapter 2.2.2.

INFORMATION

After changing the battery, the time for starting the touch probe (reboot) is approx. 5 s!

8. When using PP41.00, HPP41.10 or MY21.00 align the stylus to the spindle centre.
9. Calibrate the probe.

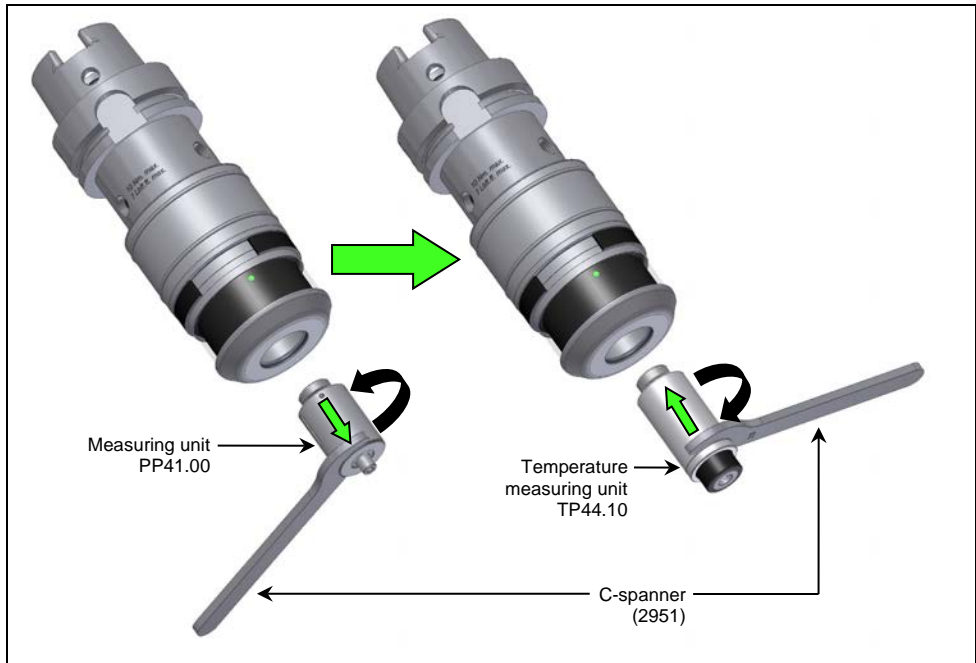

Fig. 20 Replacing measuring unit (Example: PP41.00 -> TP44.10)

2.5 Replacing Measuring Unit (UTP47.10)

NOTICE

Risk of damage to the equipment!

- Clean and dry the probe well before opening!
- Do not use compressed air to clean the touch probe!
- When inserting the new measuring unit, ensure that the O-rings inside the touch probe housing and on the measuring unit are properly seated!

1. Remove the battery from the touch probe according to chapter 2.2.2.
2. Loosen the clamping screws (3x) on ultrasonic measuring unit UTP47.10 using a hexagon key AF2 mm.
3. Carefully unscrew the measuring unit by hand in a counter-clockwise direction.
4. Insert the new measuring unit into the touch probe and carefully screw it in by hand in a clockwise direction.
5. Tighten the clamping screws (3x) on ultrasonic measuring unit UTP47.10 using a hexagon key AF2 mm.
6. Reinsert the battery into the touch probe according to chapter 2.2.2.

INFORMATION

After changing the battery, the time for starting the touch probe (reboot) is approx. 5 s!

7. Calibrate the probe.

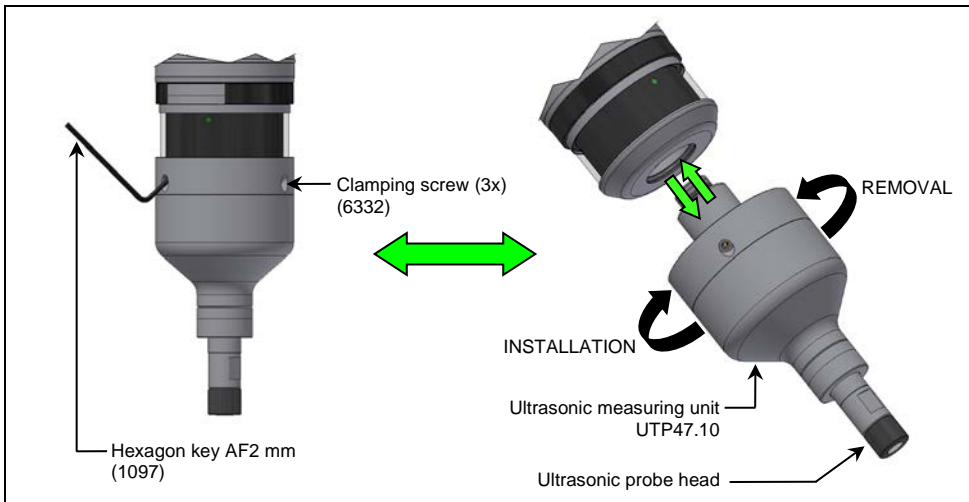

Fig. 21 Installing/removing ultrasonic measuring unit UTP47.10

2.6 Adjusting Trigger Force (Measuring Unit PP41.00 only)

INFORMATION

In the case of strong vibrations in the machine or when using heavy probe inserts, an increase in the trigger force may improve the measuring results.

1. Unscrew the stylus (refer to chapter 2.2.1).
2. Use an AF1.3 mm hexagon key to increase or decrease the trigger force (refer to Fig. 22).

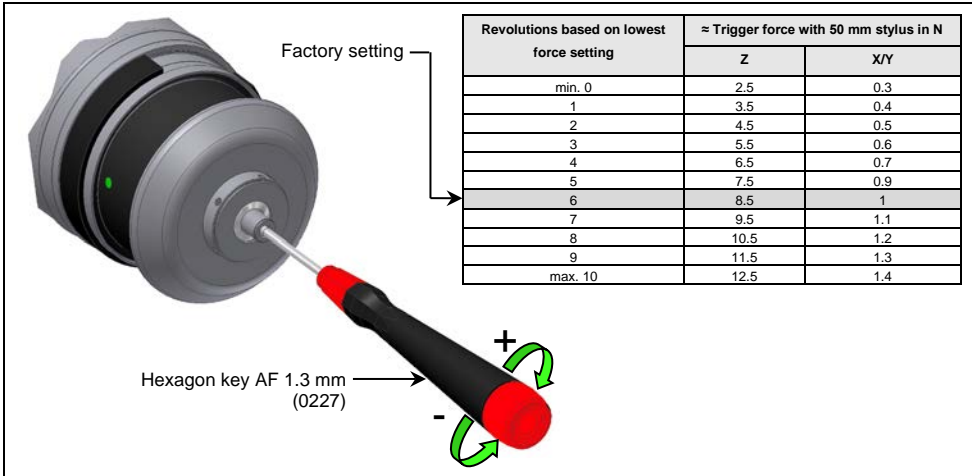

Fig. 22 Adjusting trigger force

3. Screw in the stylus (refer to chapter 2.2.1) and align the stylus to the spindle centre (refer to chapter 2.2.4).
4. Calibrate the probe.

2.7 Maintenance and Cleaning (Measuring Unit PP41.00, HPP41.10 only)

NOTICE

Risk of damage to the equipment!

- Clean and dry the probe well before opening!
- Do NOT clean with compressed air or high pressure water!
- Do NOT use any sharp tools (these could damage the inner seal)!

1. Unscrew the stylus.

INFORMATION

Dirt can collect under the metal eyelid.

2. Remove the service cover with metal eyelid and conical spring by hand.
3. Clean the touch probe and components under running water.
4. Reassemble all parts.
5. Align the stylus to spindle centre.
6. Calibrate the probe!

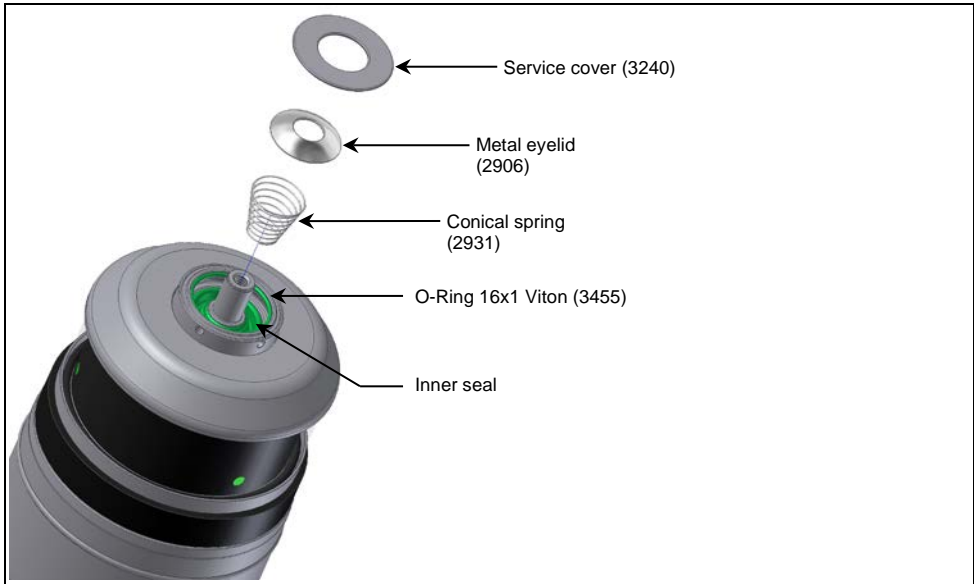

Fig. 23 Maintenance and cleaning of the radio-wave touch probe RWP20.50-G

2.8 Measuring the temperature with temperature measuring unit TP44.10

INFORMATION

The following points must be observed during temperature measurement:

- Probing should always be done at a right angle to the measuring surface.
- The surface must always be clean.
- The measurement process described here must be adhered to.
- When using a measured temperature to correct working dimensions, a second control measurement and a comparison must be carried out.

2.8.1 Temperature Measurement Process

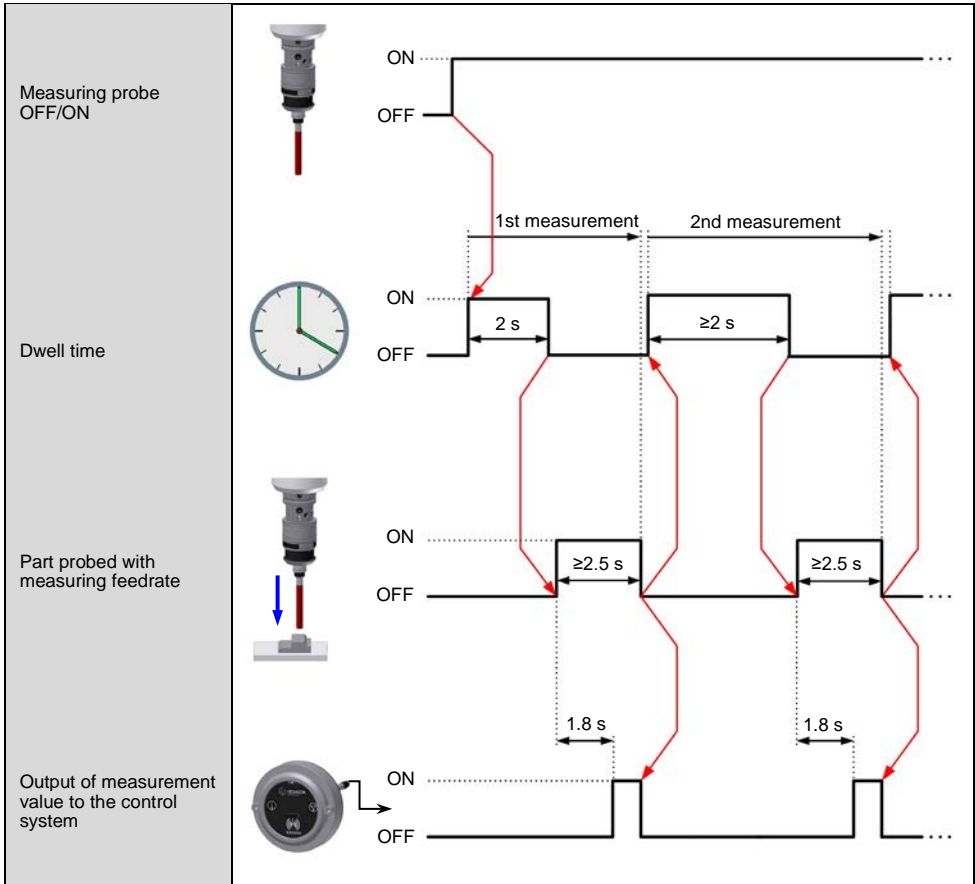

2.8.2 Temperature Measurement: Example Applications

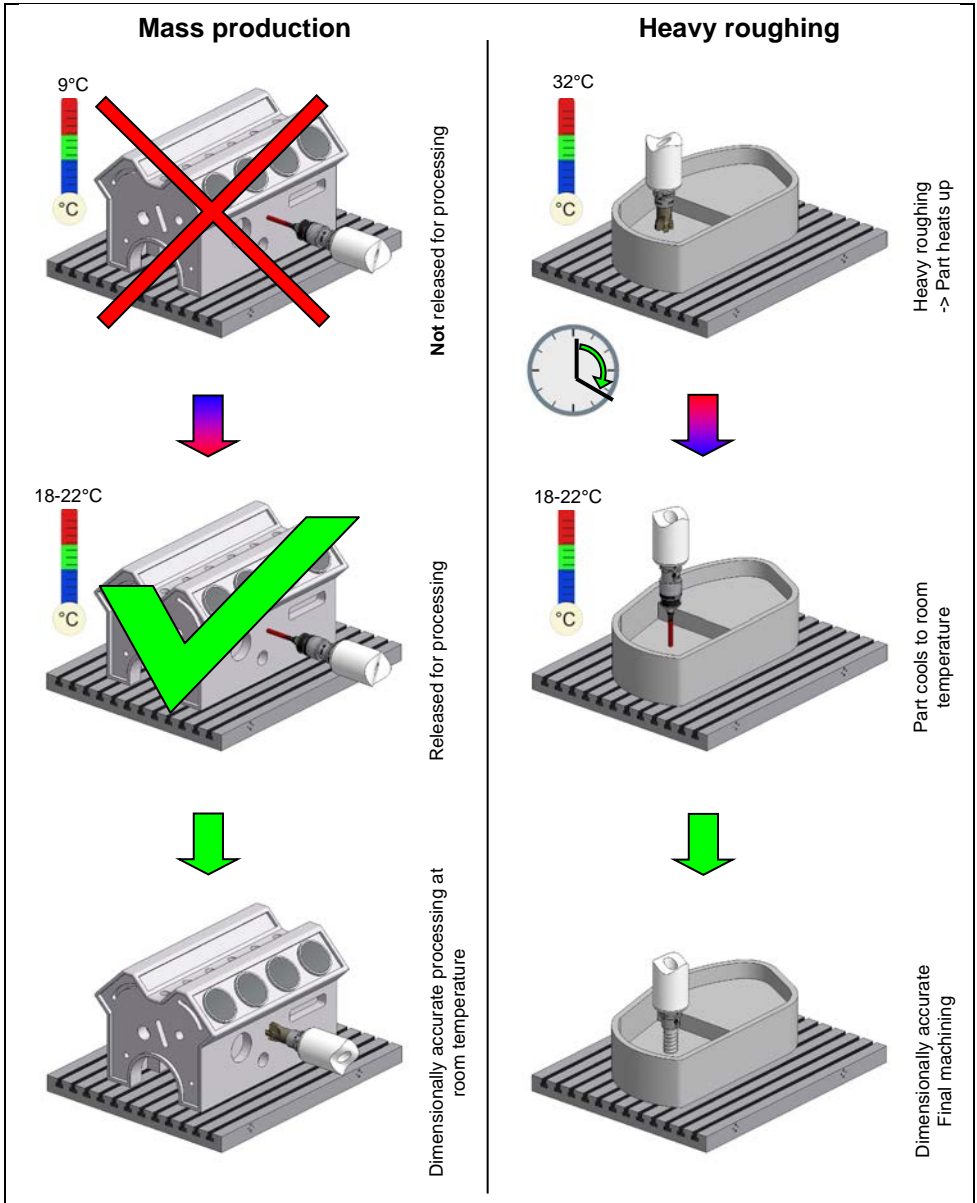

Fig. 24 Temperature Measurement: Example Applications

2.9 Ultrasonic measurement with ultrasonic measuring unit UTP47.10

NOTICE

Risk of damage to the ultrasonic probe head when using mineral cooling lubricants!

The use of mineral cooling lubricants may result in disintegration on the tip of the ultrasonic probe head.

- Perform ultrasonic measurements only when dry or with minimal lubrication!
- Only use suitable and approved cooling lubricants
(A list of suitable cooling lubricants is available from m&h)

INFORMATION

Ultrasonic measurement is only possible in conjunction with radio-wave receiver RWR95.51.
This function is not supported when using m&h radio-wave receiver RWR95.50.

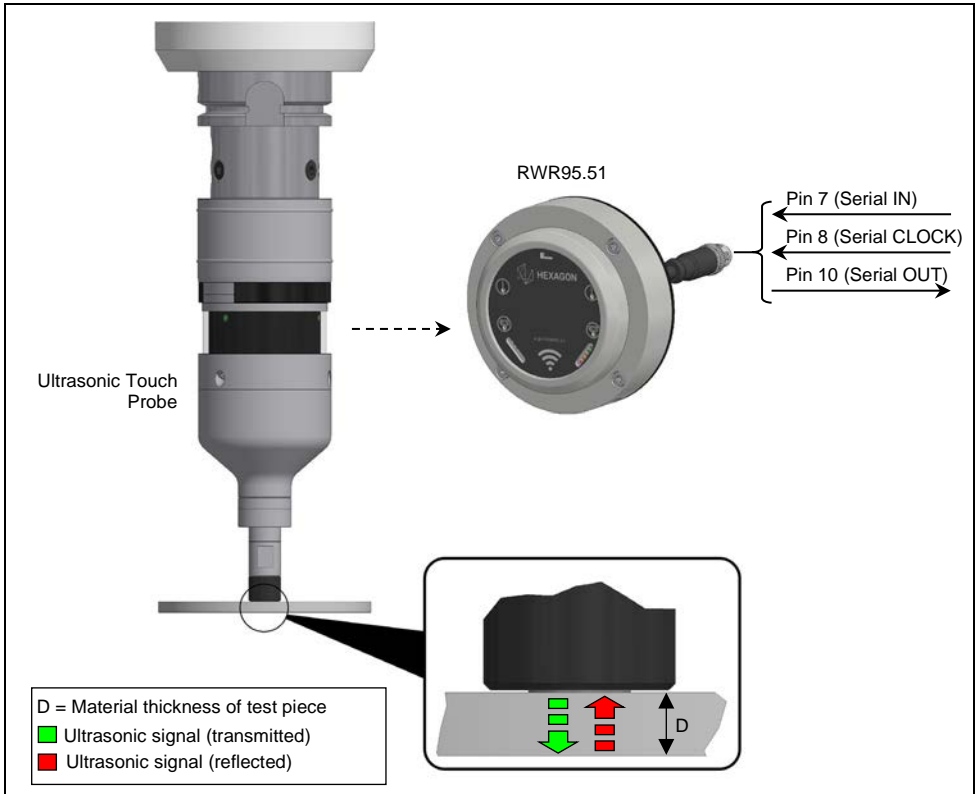

Fig. 25 Ultrasonic measurement

2.10 Probe Extension

NOTICE

Risk of material damage/damage to the equipment!

- Wipe the probe clean and dry before dismounting!
- Do not use compressed air to clean the touch probe!
- When assembling the extension, ensure the O-rings are properly seated.
- Aligning stylus to spindle centre.
- Calibrate the touch probe.

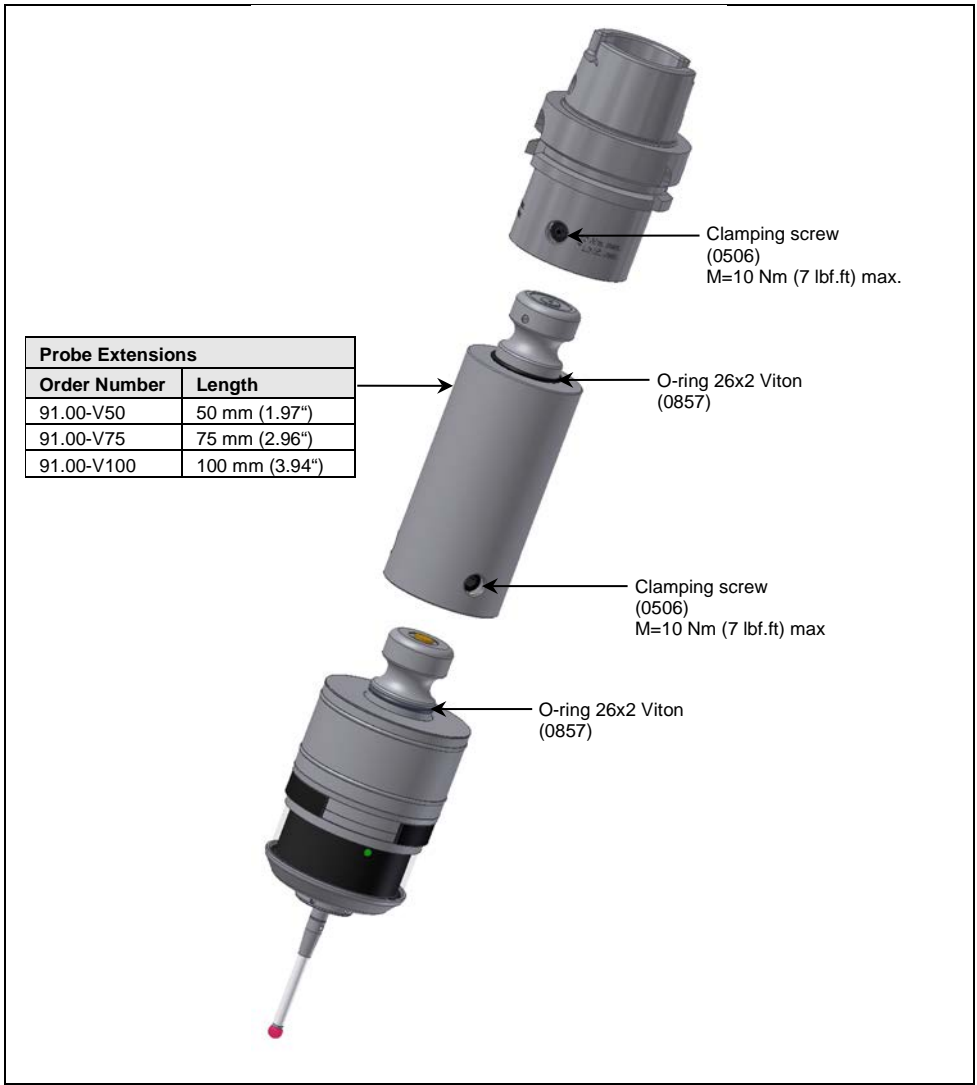

Fig. 26 Probe Extension

2.11 Modular System (for Measuring Units PP41.00 and MY21.00 only)

NOTICE

Risk of material damage/damage to the equipment!

- Wipe the probe clean and dry before dismounting!
- Do not use compressed air to clean the touch probe!
- When screwing in the extension, make sure the O-ring is properly seated.
- The probe may be extended by a maximum of 400 mm!
- Align probe in the spindle axis to the spindle centre.
- Calibrate the touch probe.

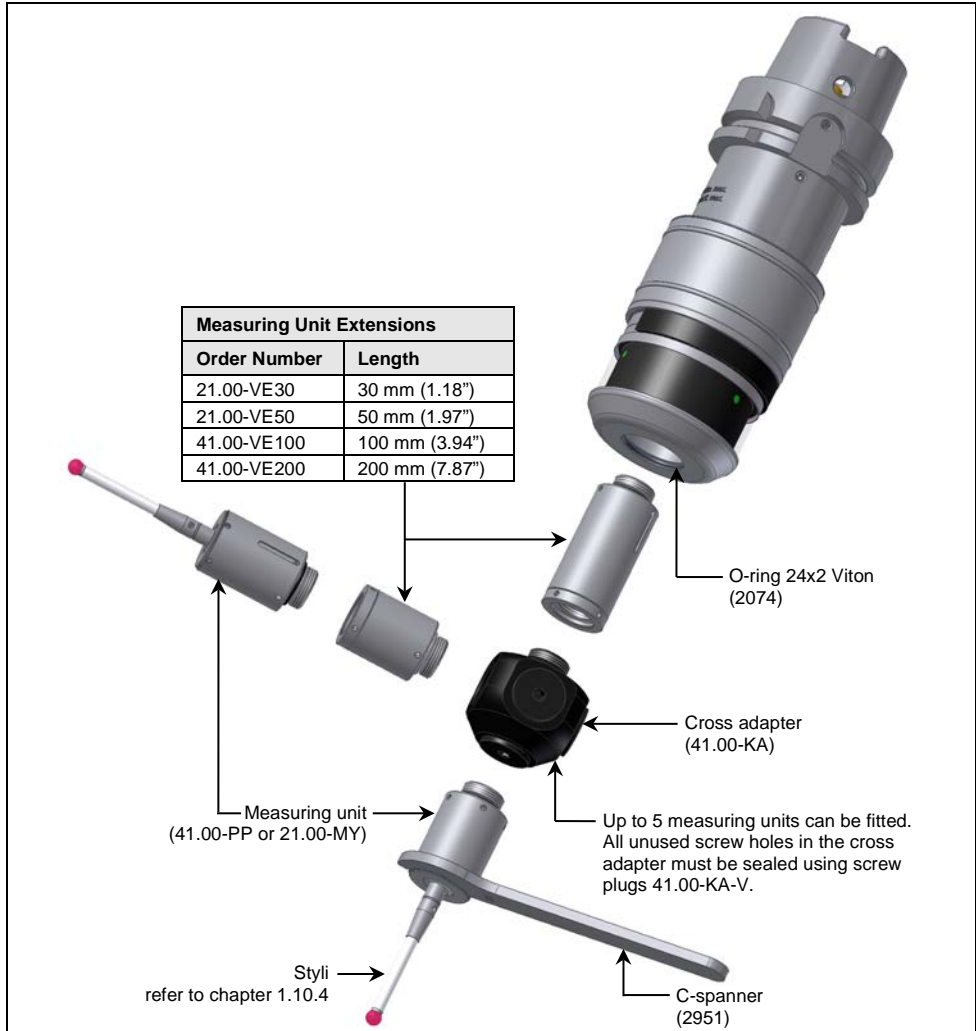

Fig. 27 Modular system

EU Declaration of Conformity

This declaration of conformity is issued under the sole responsibility of m&h Inprocess Messtechnik GmbH.

Manufacturer /
Representative: **m&h Inprocess Messtechnik GmbH**
Am Langholz 11
88289 Waldburg
Germany

Product name: **Radio-wave Touch Probe**

Model / Type: **RWP20.50-G**

The product mentioned above meets the requirements of the following relevant directives / standards.

Directive / Standard	Issue	Title / Section
2011/65/EU	2011	Restriction of the use of certain hazardous substances in electrical and electronic equipment
2014/53/EU	2014	Making radio equipment available on the market
2014/30/EU	2014	Electromagnetic compatibility
DIN EN 61326-1	2013	Electrical equipment for measurement, control and laboratory use - EMC requirements - Part 1
DIN EN 61326-2-2	2013	Electrical equipment for measurement, control and laboratory use - EMC requirements - Part 2-2
DIN EN 55011	2017	Industrial, scientific and medical equipment - Radio-frequency disturbance characteristics - Limits and methods of measurement
DIN EN 300328	2017	Wideband transmission systems - Data transmission equipment operating in the 2,4 GHz ISM band and using wide band modulation techniques
DIN EN 301489-1	2017	ElectroMagnetic Compatibility (EMC) standard for radio equipment and services - Part 1
DIN EN 301489-3	2013	ElectroMagnetic Compatibility (EMC) standard for radio equipment and services - Part 3
DIN EN 301489-17	2017	ElectroMagnetic Compatibility (EMC) standard for radio equipment and services - Part 17
DIN EN 12100	2011	Safety of machinery - General principles for design - Risk assessment and risk reduction



Waldburg, 31.07.2017

Place, Date



Wolfgang Madlener, General Manager





Hexagon Manufacturing Intelligence helps industrial manufacturers develop the disruptive technologies of today and the life-changing products of tomorrow. As a leading metrology and manufacturing solution specialist, our expertise in sensing, thinking and acting – the collection, analysis and active use of measurement data – gives our customers the confidence to increase production speed and accelerate productivity while enhancing product quality.

Through a network of local service centres, production facilities and commercial operations across five continents, we are shaping smart change in manufacturing to build a world where quality drives productivity. For more information, visit HexagonMI.com.

Hexagon Manufacturing Intelligence is part of Hexagon (Nasdaq Stockholm: HEXA B; hexagon.com), a leading global provider of information technologies that drive quality and productivity across geospatial and industrial enterprise applications.

-  COORDINATE MEASURING MACHINES
-  3D LASER SCANNING
-  SENSORS
-  PORTABLE MEASURING ARMS
-  SERVICES
-  LASER TRACKERS & STATIONS
-  MULTISENSOR & OPTICAL SYSTEMS
-  WHITE LIGHT SCANNERS
-  METROLOGY SOFTWARE SOLUTIONS
-  CAD / CAM
-  STATISTICAL PROCESS & CONTROL
-  AUTOMATED APPLICATIONS
-  MICROMETERS, CALIPERS AND GAGES
-  DESIGN AND COSTING SOFTWARE

m&h Inprocess Messtechnik GmbH

Am Langholz 11
88289 Waldburg
Germany

Tel. +49 (0)7529 9733 0
Fax +49 (0)7529 9733 7
sales.mh@hexagon.com
www.mh-inprocess.com

m&h – Part of Hexagon Manufacturing Intelligence